



Stroking Skills
Manual

Effective from
1 January 2016

ACKNOWLEDGEMENT

The new Stroking tests have been adapted, with permission, from the United States Figure Skating Association's Moves in the Field tests. The NZIFSA would like to acknowledge the USFSA for their support.

GENERAL REQUIREMENTS

- The Stroking Tests are basic skating moves skated with or without music as an optional choice.
- The terms and judging standards applied are as for basic skating.
- The elements in the Stroking Tests shall be skated in the order as set forth in the schedule of tests.
- Stroking turns must be judged in accordance with the criteria set forth in the corresponding Test Rules.
- Stroking must be commenced from a standing, stationary position with a minimum number of introductory steps.
- If a skater starts a move on the wrong foot or skates a move other than that prescribed, the Referee must draw attention to the mistake as soon as possible. The mistake must be treated as a false start.
- Such fresh start must be allowed only once.
- Skaters shall select the area on the ice surface for the Stroking Test, directed by the Referee.

BASIC RULES FOR STROKING

An effortless, flowing and graceful execution should be achieved. Within the limits of the following rules, complete freedom is allowed to the skater.

- The head should be carried in an upright position, relaxed and naturally held
- The upper body should be upright but not stiff
- The arms should be held gracefully
- The free leg should be extended with the toe pointed

The steps must be skated in accordance with the diagrams and descriptions. The number of steps must be skated as prescribed. Subject to a general conformity with the basic requirements, complete freedom is allowed to the skater with respect to arm and free leg positions.

Stroking must be skated with good edges, control, flow, extension, carriage and rhythm. An even speed and flow should be maintained throughout. Maximum utilisation of the ice surface is desirable. Ice coverage must not be obtained by the use of flat or shallow edges.

MARKING

Stroking will be judged on a pass/fail basis for each element. In determining this result consideration will be given to:

- a) Accuracy – the correct start, steps and adherence to the general pattern
- b) Edge Quality – characterised by a stable arc and controlled body rotation, the edge ideally without subcurves or wobbles, initiated by placing the body and blade on an angle to the surface of the ice and stepping on the required edge. This edge and arc will ideally commence immediately at the point where the skater takes the ice and travels uninterrupted until a required transition takes place
- c) Extension – the controlled stretching of the free leg complimented by an upright body posture. The height of the extension is determined by the type of movement being executed as is the extension of the upper body. The final extended position should always be attained in a controlled fashion
- d) Quickness – quickness refers to foot speed. It is the precise, rapid and crisp execution of turns, change of edge and transitions, usually in a brisk and continuous cadence. Refinements to acknowledge include quick movement that is quiet, fluid and continuous without disturbing the proper and erect carriage of the upper body and without interrupting the established rhythm.
- e) Power – power is obvious and rapid acceleration, often from a standstill position, achieved by a forceful, gripping pressure exerted by the skating leg and skate against the surface of the ice. Power includes maintaining or increasing speed while executing various skating elements. Power is relative to the size of the skater but can be attained with proper stroking technique.

COMMON ERRORS, AREAS OF DIFFICULTY & TEST EXPECTATIONS

The Common Errors (CE), Areas of Difficulty (AD), and Test Expectations (TE) are listed for each of the elements the Stroking Skills tests. These notes should be read in conjunction with the requirements for each element of each test level.

STROKING TESTS - INDEX TO STROKING REQUIREMENTS

| | | |
|---------------------|---------------|--|
| ELEMENTARY | TEST 0 | Perimeter Stroking (Forward & Backward) Basic Consecutive Edges |
| PRELIMINARY | TEST 1 | Waltz Eight Forward and Backward Crossovers Spiral Step Sequence Forward Power 3-Turns Alternating Forward Inside Three-Turns Alternating Backward Crossovers to Backward Outside Edges |
| INTER BRONZE | TEST 2 | Forward and Backward Perimeter Power Stroking 3-Turns in the Field - FO BI 3-Turns in the Field - FI BO Forward and Backward Power Change of Edge Pulls Five step Mohawk Sequence |
| BRONZE | TEST 3 | Stroking: Forward Power Circle Stroking: Backward Power Circle Eight Step Mohawk Sequence Forward and Backward Free Skating Cross Strokes Backward Power Three-Turns Forward Double Three-Turns |
| INTERSILVER | TEST 4 | Backward Double Three-Turns Spiral Sequence Brackets in the Field Sequence Forward Twizzles Inside Slide Chassé Pattern |
| SILVER | TEST 5 | Inside Three-Turns/ Rocker Choctaws Forward and Backward Outside Counters Forward and Backward Inside Counters Forward Loops Backward Swing Rocker Sequence Backward Twizzles |
| INTERGOLD | TEST 6 | Forward and Backward Outside Rockers Forward and Backward Inside Rockers Power Pulls Choctaw Sequence Backward Loop Pattern Straight Line Step Sequence |
| GOLD | TEST 7 | Sustained Edge Step Spiral Sequence Backward Outside Power Double 3-Turns to Power Double Inside Rockers Backward Inside Power Double 3-Turns to Power Double Outside Rockers Serpentine Step Sequence |
| GOLD STAR | TEST 8 | Accelerating Mohawks, Choctaws and Gallops Creative Exercises Expanding Exercises CW, CCW |

ELEMENTARY (TEST 0) STROKING SKILLS TEST

1. Perimeter Stroking (Forward & Backward)
2. Basic Consecutive Edges

ELEMENTARY STROKING SKILLS TEST

DESCRIPTION

1. Perimeter stroking

The skater will perform four to eight straight strokes depending on the length of the ice and the strength of the skater, with crossovers around the end, using the full ice surface for half of the circumference of the rink. The skater will then turn to backwards using either a two foot turn or a three-turn (free choice) and complete the lap of the rink using backwards strokes and crossovers instead of forwards. This exercise is done in both directions. Introductory steps are optional.

Focus: Power and extension

COMMON ERRORS, AREAS OF DIFFICULTY & TEST EXPECTATIONS

1. Perimeter Stroking

FOCUS: Power and extension

| | |
|----|--|
| CE | Toe pushing Poor posture Poor extension |
| AD | Generally clockwise direction crossovers Proper use of blade to stroke Equal power on both pushes of crossovers |
| TE | Stroking slightly onto a flat Generally clockwise direction weaker than counter-clockwise Occasional toe pushing |

1. Perimeter Stroking (Forward and Backward)

FOCUS: Power and extension

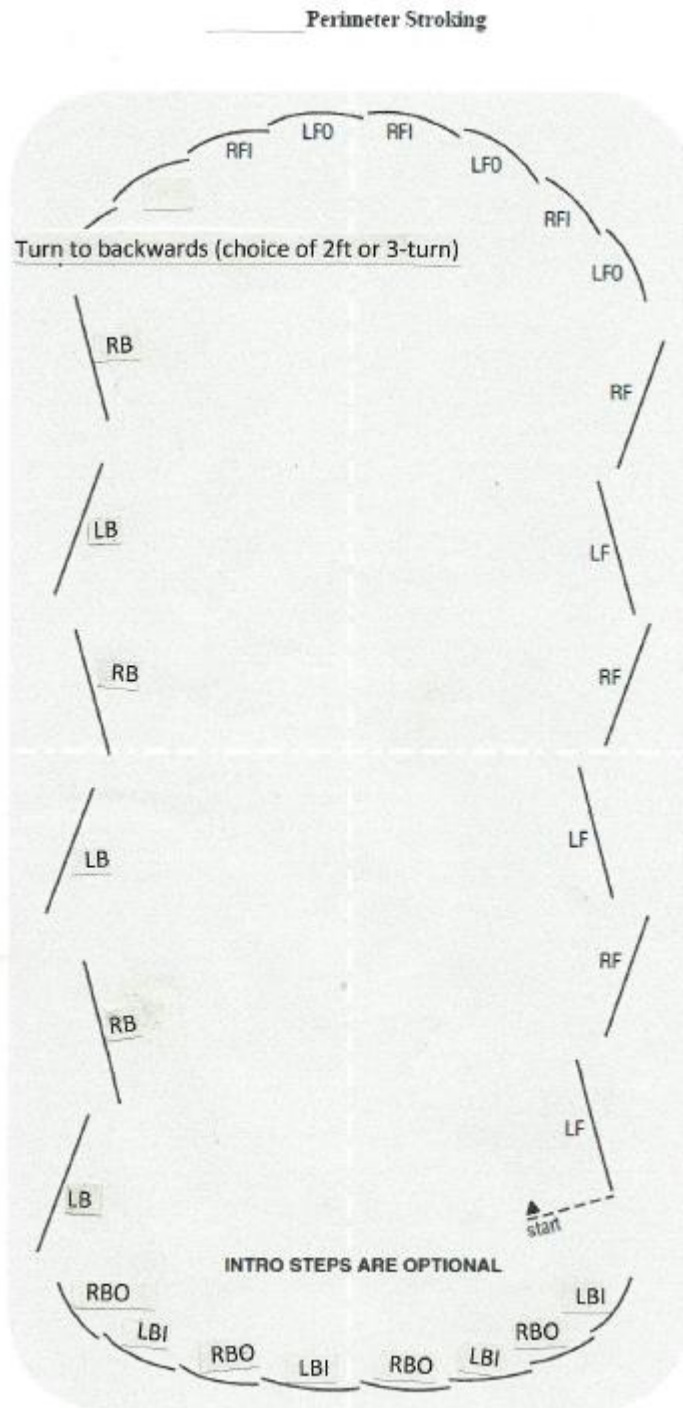

ELEMENTARY (TEST 0) STROKING SKILLS TEST

DESCRIPTION

2. Basic consecutive edges Forward outside edges Forward inside edges Backward outside edges Backward inside edges Starting from a standing position the skater will perform four to six half circles, alternating feet, using an axis line such as a hockey line. The skater may start each set on either foot, but they must be skated in the order listed. **Focus: Edge quality**

COMMON ERRORS, AREAS OF DIFFICULTY & TEST EXPECTATIONS

2. Basic Consecutive Edges

FOCUS: Edge quality

| | |
|----|--|
| CE | Toe pushing Not initiating edges perpendicular to the axis Back edges weaker than forward Inability to control positions |
| AD | Control during second half of back outside edges Control throughout the back inside edges (lack of control due to inability to check upper body rotation) Ability to control upper body rotation |
| TE | Fairly steady half circles Initiating edge as close to perpendicular as possible Fairly good control of body positions |

Basic Consecutive Edges

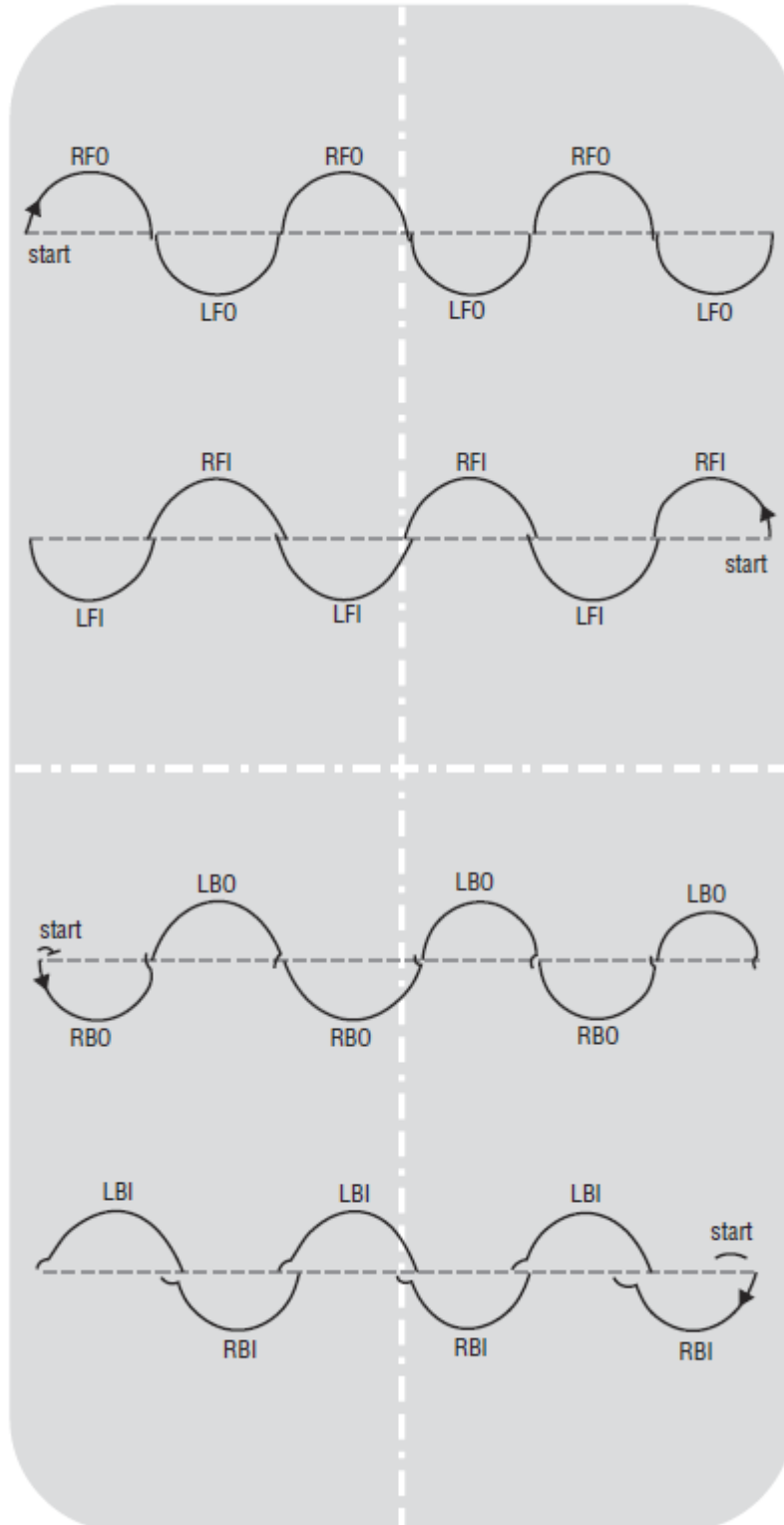

PRELIMINARY (TEST 1) STROKING SKILLS TEST

1. Waltz Eight
2. Forward and Backward Crossovers
3. Spiral Step Sequence
4. Forward Power 3-Turns
5. Alternating Forward Inside Three-Turns
6. Alternating Backward Crossovers to Backward Outside Edges

PRELIMINARY (TEST 1) STROKING SKILLS TEST

DESCRIPTION

1. Waltz Eight

The skater will perform the Waltz Eight, using large circumference circles, completing two patterns on each foot, and performed with control. This move may start on either foot. Introductory steps are optional or may begin from a standing start. The skater may mark their centre.

Focus: Edge quality

COMMON ERRORS, AREAS OF DIFFICULTY & TEST EXPECTATIONS

1. Waltz Eight

FOCUS: Edge quality

| | |
|----|--|
| CE | <ul style="list-style-type: none">-Not skating the waltz eight with an even rhythm or timing-Back outside edge too short-Not dividing the circle into thirds |
| AD | <ul style="list-style-type: none">-Checking after the forward three turn-Stepping forward after the back outside edge-Controlling the forward outside edge into centre-Ability to control upper body rotation and positions |
| TE | <ul style="list-style-type: none">-Show reasonable control of body positions and edges-Circle size should be approximately twice the skater's height-Should come back to a common centre |

Waltz Eight

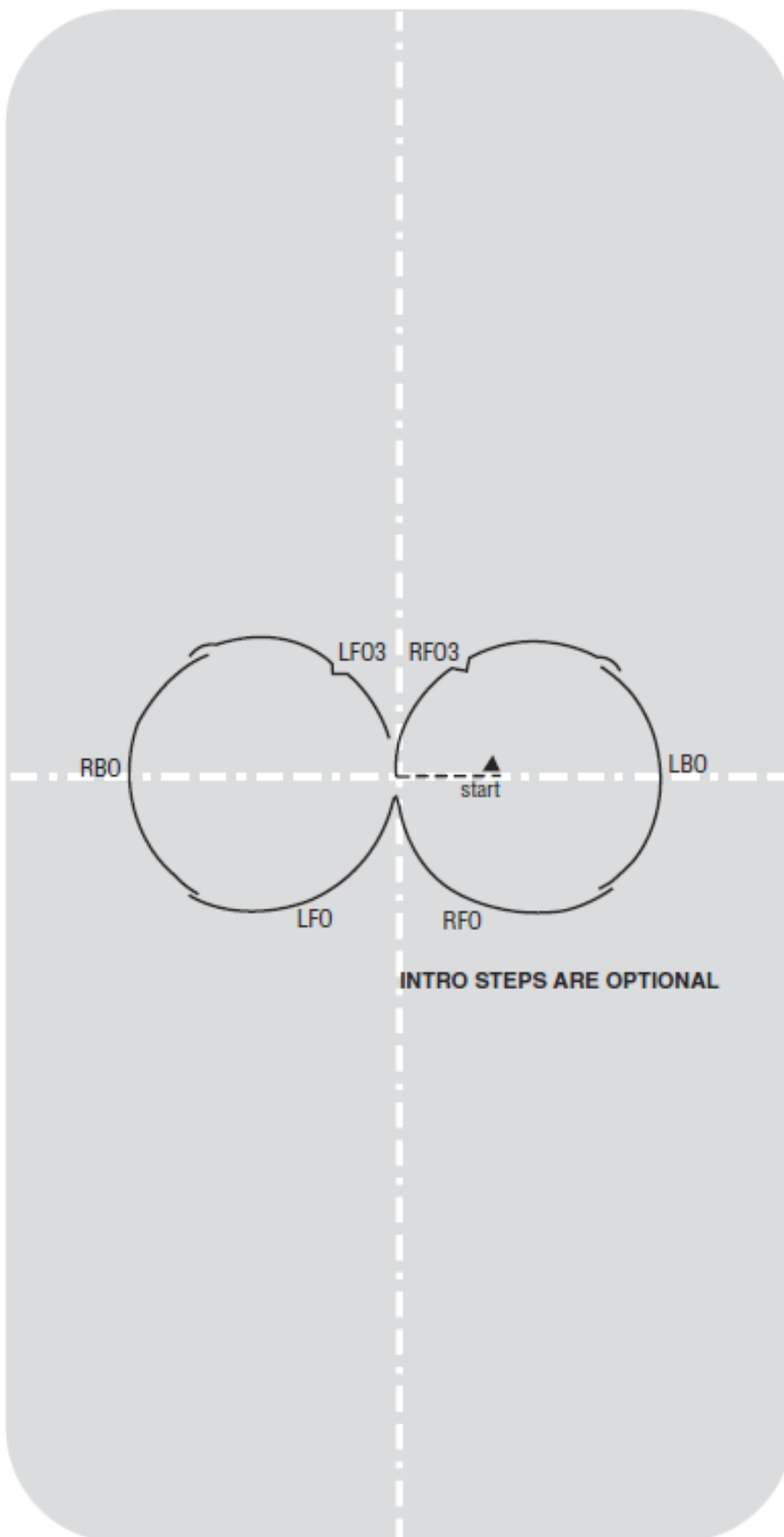

PRELIMINARY (TEST 1) STROKING SKILLS TEST

DESCRIPTION

2. Forward and backward crossovers

The skater will perform forward crossovers in a figure eight pattern. It is expected that the skater will perform the transition between circles on one foot. Four to six crossovers per circle are recommended. Upon completing the forward figure eight, the skater will perform a swing roll and change of edge to an open mohawk in order to turn from forward to backward and continue the figure eight pattern with four to six backward crossovers per circle. This move may start in either direction. Introductory steps are optional.

Focus: Power

COMMON ERRORS, AREAS OF DIFFICULTY & TEST EXPECTATIONS

2. Forward and Backward Crossovers

FOCUS: Power

| | |
|----|---|
| CE | <ul style="list-style-type: none">-Slight toe pushing or incorrect use of blade to stroke-Forward crossovers weaker than back crossovers-Incomplete second stroke on both forward and backward crossovers-Up and down motion throughout the crossovers-Poor posture |
| AD | <ul style="list-style-type: none">-Clockwise direction of the forward crossovers-Ability to create power-Equal power from both strokes |
| TE | <ul style="list-style-type: none">-Fair posture, shows some ability to increase power with each crossover-Give additional credit when skated in a larger pattern (indicates more power)-No consistent toe pushing. |

Forward & Backward Crossovers

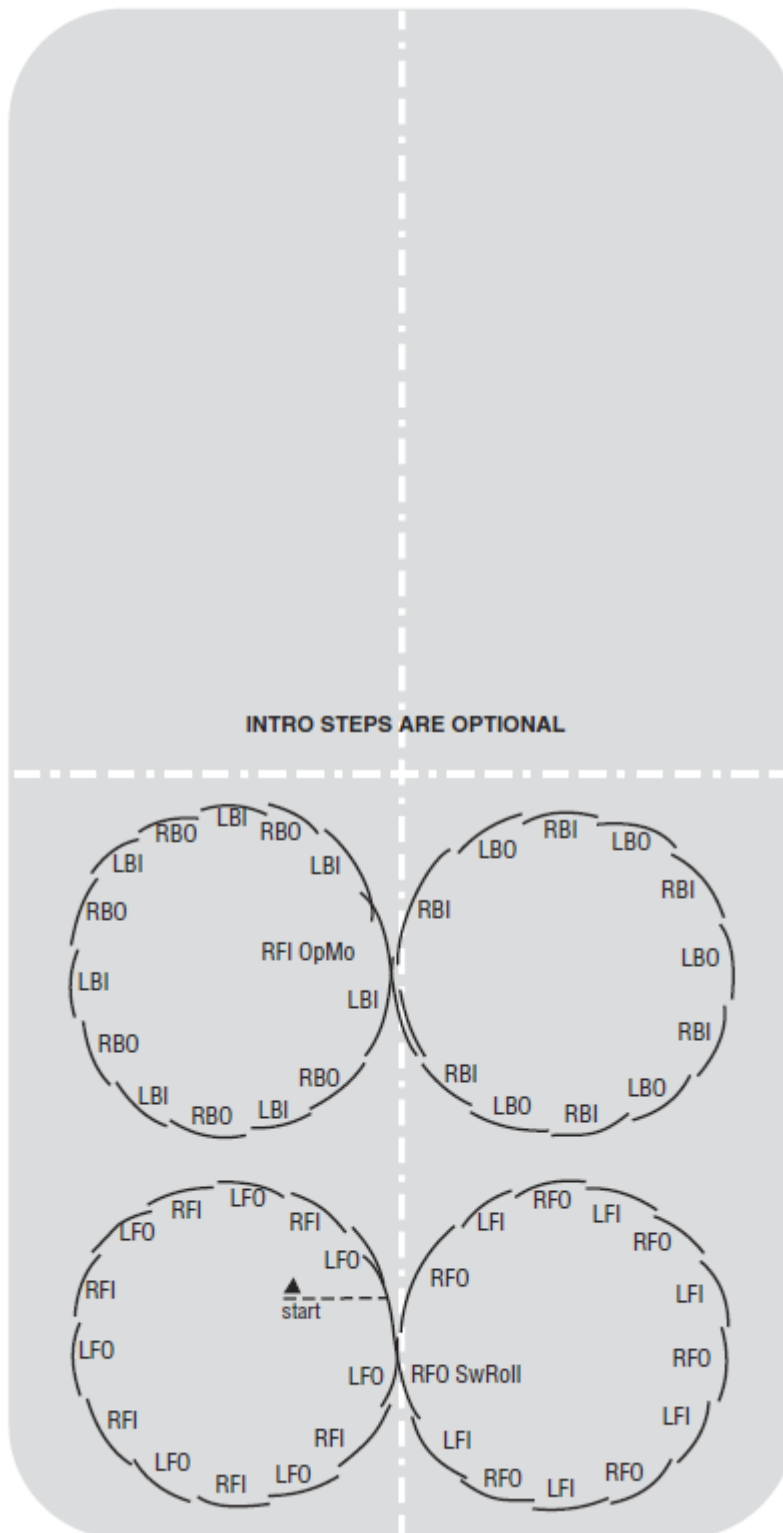

PRELIMINARY (TEST 1) STROKING SKILLS TEST

DESCRIPTION

3. Spiral step sequence

The skater will perform a circular or serpentine step sequence (or a combination of these) consisting primarily of spirals which must include forward inside and forward outside spirals that are executed on both left and right foot (i.e. minimum of four spirals). Pushes in order to gain speed are permitted. Connecting steps turns and small jumps are permitted at any point in the sequence. Except during such pushes, steps, turns or small jumps, the skater must be primarily in a spiral position; that is with the free leg higher than hip level. Variations are permitted including holding the knee or blade.

Focus: Extension and edge quality

COMMON ERRORS, AREAS OF DIFFICULTY & TEST EXPECTATIONS

3. Spiral Step Sequence

FOCUS: Extension and edge quality

| | |
|----|--|
| CE | <ul style="list-style-type: none">-Free leg on spiral is not higher than hip level-Poor speed-Poor extension of free leg-Toe pushing-Spirals not skated on edges |
| AD | <ul style="list-style-type: none">-Forward inside spirals-Maintaining speed throughout-Edges maintained during spiral |
| TE | <ul style="list-style-type: none">-Minimum bend in free leg position-Spirals skated on edges (not necessarily strong edges)-Free leg position is higher than hip height-Minimal toe pushing-Speed maintained throughout sequence |

This page has been deliberately left blank. There is no prescribed pattern for this exercise.

PRELIMINARY (TEST 1) STROKING SKILLS TEST

DESCRIPTION

4. Forward power three-turns

The skater will perform forward outside three-turns to a balance position followed by a backward crossover. Three to six sets of three-turns will be skated depending on the length of the ice surface. Skaters may begin this move with either right or left foot three-turns. On the second length of the rink, the three-turns will be skated on the opposite foot. Introductory steps and backward crossovers around the end of the rink are optional.

Focus: Power

COMMON ERRORS, AREAS OF DIFFICULTY & TEST EXPECTATIONS

4. Forward Power Three-Turns

FOCUS: Power

| | |
|----|--|
| CE | <ul style="list-style-type: none">-After the forward three-turn as the skater is changing feet, they will shift onto a back outside edge instead of a back inside edge-Inability to create power from the BI edge of the weight shift into the back crossover-Uneven timing-Too noisy due to skater using toepicks instead of the edges to stroke-Lack of control of free leg and upper body-Poor posture |
| AD | <ul style="list-style-type: none">-Usually the right forward three-turns-Ability to create power |
| TE | <ul style="list-style-type: none">-Nice flow and power throughout (Preliminary level power)-Skater demonstrates control throughout-Ability to maintain an axis throughout the move |

Forward Power Three-Turns

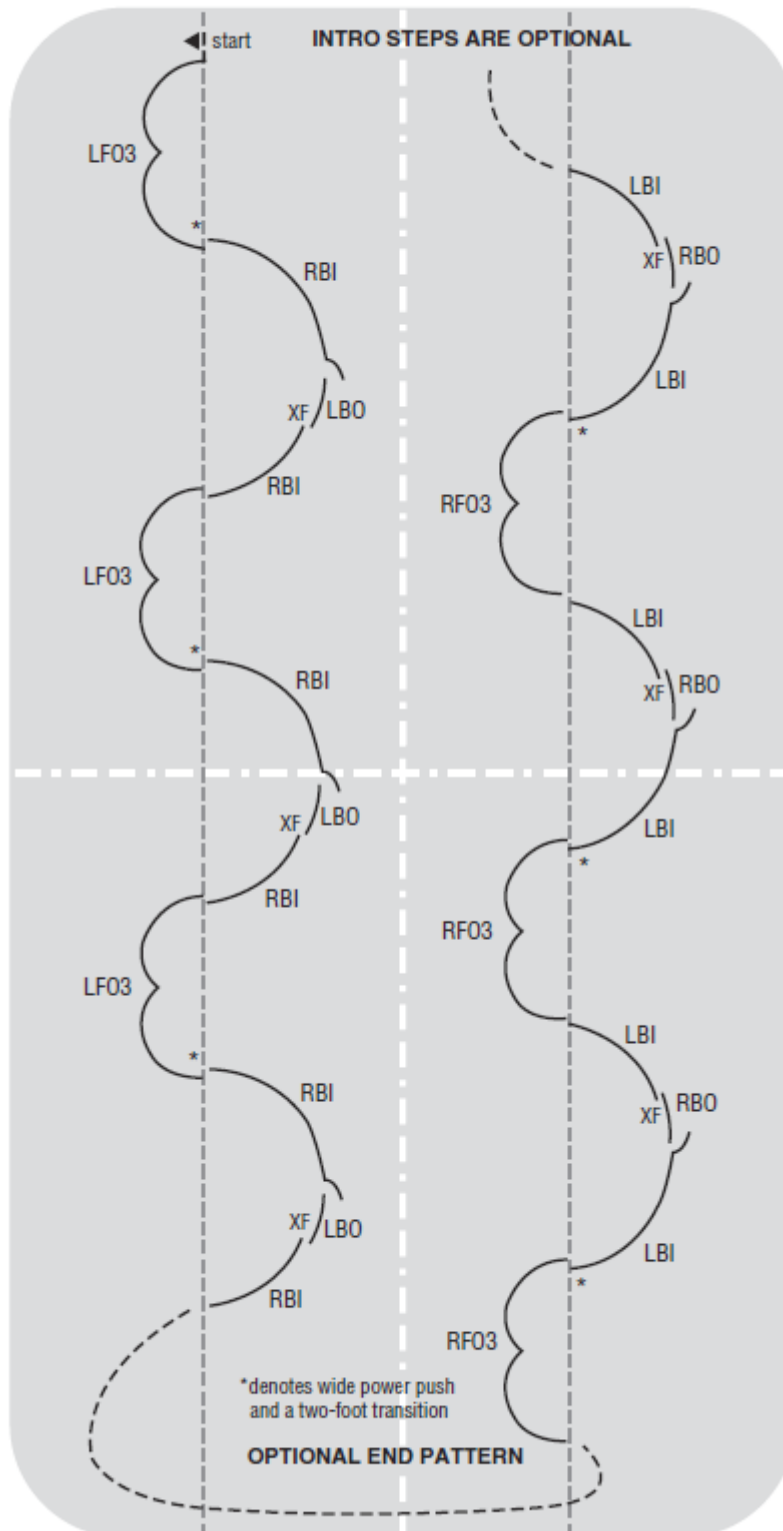

PRELIMINARY (TEST 1) STROKING SKILLS TEST

DESCRIPTION

5. Alternating forward inside three-turns

Starting from a standing position the skater will perform alternating forward inside three-turns for the width of the rink. The size of the rink and strength of the skater will determine the number of three- turns skated. This move may start on either foot.

Focus: Edge quality

COMMON ERRORS, AREAS OF DIFFICULTY & TEST EXPECTATIONS

5. Alternating forward inside three turns

FOCUS: Edge quality

| | |
|----|---|
| CE | <ul style="list-style-type: none">-Three-turns placed early-Inability to control after the three-turns and after the transition from backward to forward-Incorrect placement of the blade in relation to the axis-Lobes too large-Poor flow |
| AD | <ul style="list-style-type: none">-FI three-turns-Controlling the BO-FI transition |
| TE | <ul style="list-style-type: none">-Give additional credit when skated with an extended free leg-Give additional credit when skater demonstrates good control after the transition-Turns should be close to the top of the lobes-Beginning edge should be initiated as close to perpendicular to the axis as possible |

5. Alternating forward inside three turns

FOCUS: Edge quality

Alternating Forward Three-Turns

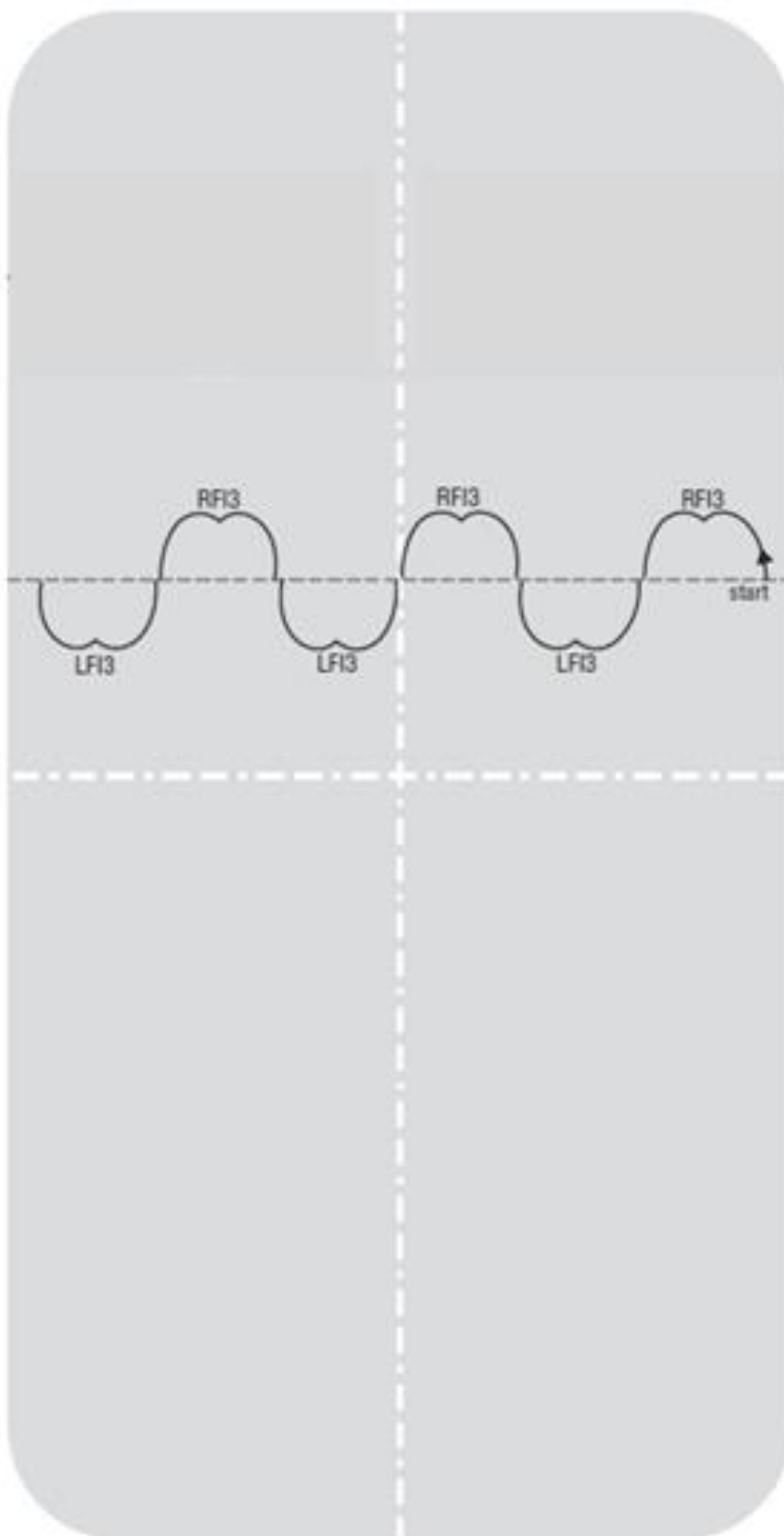

PRELIMINARY (TEST 1) STROKING SKILLS TEST

DESCRIPTION

6. Alternating backward crossovers to backward outside edges

The skater will perform alternating backward crossovers to backward outside edges in consecutive half circles for one length of the rink. Four or five lobes should be skated. Introductory steps are optional.

Focus: Power and extension

COMMON ERRORS, AREAS OF DIFFICULTY & TEST EXPECTATIONS

6. Alternating backward crossovers to backward outside edges

FOCUS: Power and extension

| | |
|----|--|
| CE | <ul style="list-style-type: none">-Generally left back outside extension weaker-Poor flow-Change of edge on the back extension |
| AD | <ul style="list-style-type: none">-Good posture-Equal quality of the extension on both legs |
| TE | <ul style="list-style-type: none">-Maintains good speed (for Preliminary level)-Fair to good posture-Fairly good ice coverage-Good control during both extensions |

6. Alternating backward crossovers to backward outside edges
FOCUS: Power and extension

Alternating Backward Crossovers to Backward Outside Edges

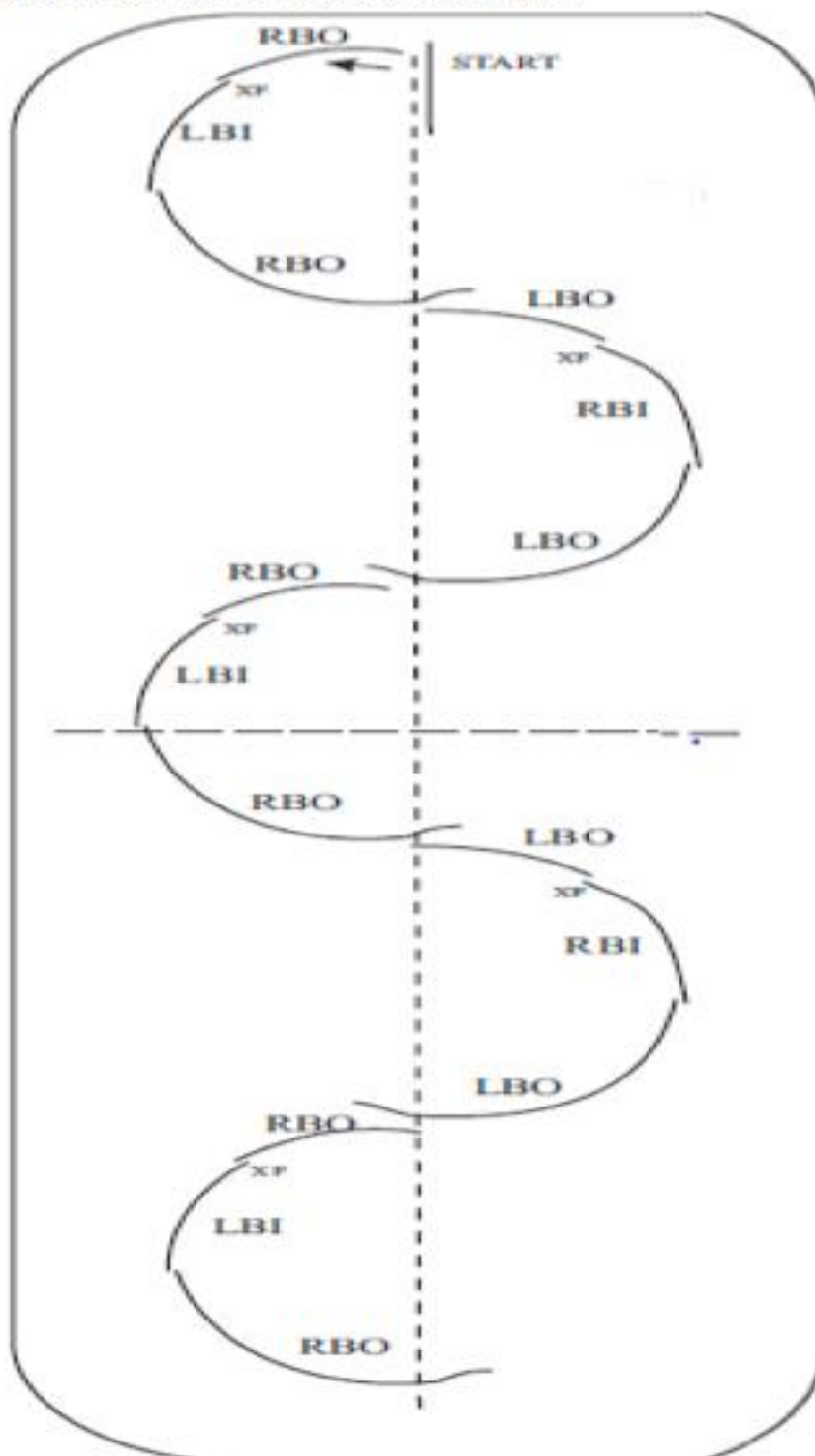

INTER BRONZE (TEST 2) STROKING SKILLS TEST

1. Forward and Backward Perimeter Power Stroking
2. Three-turns in the Field – FO BI
3. Three-turns in the Field – FI BO
4. Forward and Backward Power Change of Edge Pulls
5. Five-step Mohawk Sequence

INTER BRONZE (TEST 2) STROKING SKILLS TEST

DESCRIPTION

1. Forward and backward perimeter power stroking (anticlockwise only)

The skater will perform four alternating forward crossovers separated by strong FI edge transitions. The end pattern consists of two forward crossovers followed by a LFO open stroke; then a RFI open mohawk followed by one or two backward crossovers. All end pattern steps should be performed with an even cadence except the LFO open stroke, which should be held for two counts. The second side of the pattern resumes with four backward crossovers separated by two-foot transitions, also known as a power push. Skaters should take care to perform the transitions on two solid inside edges. The second end pattern consists of three to five backward crossovers. Introductory steps are optional.

Forward focus: Power, extension and edge quality

Backward focus: Power and edge quality

COMMON ERRORS, AREAS OF DIFFICULTY & TEST EXPECTATIONS

1. Forward and Backward Perimeter Stroking

FOCUS: Forward – Power, extension and edge quality

FOCUS: Backward – Power and edge quality

| | |
|----|--|
| CE | <ul style="list-style-type: none">-Poor speed-Incomplete second stroke on crossovers-Using toepicks instead of edges-Poor posture-Lack of power onto FI / BI edge-Poor extension on FI edge (forward)-Stepping too diagonal onto the axis for the FI/BI edge-Unequal weight shift throughout (backward) |
| AD | <ul style="list-style-type: none">-Ability to create power-Correct pattern-Maintaining a smooth or level shift of weight (backward)-Equal power demonstrated forwards and backwards |
| TE | <ul style="list-style-type: none">-Maintains good speed (for Inter Bronze level)-Both pushes in crossovers are of the same quality/strength-Good ice coverage-No toe pushing-Two foot glide to be used for power and not as a hold (backward) |

INTER BRONZE (TEST 2) STROKING SKILLS TEST

DESCRIPTION

2. FO-BI three-turns in the field

The skater will perform two sets of forward outside three-turns alternating to backward inside three-turns covering approximately half the length of the rink. One half of the rink will be RFO-LBI three-turns. The skater will perform LFO-RBI three-turns on the other half of the rink. Introductory steps are optional, as are the steps to transition to the second half. This move may start on either foot.

Focus: Edge quality

COMMON ERRORS, AREAS OF DIFFICULTY & TEST EXPECTATIONS

2. FO-BI Three-turns in the field

FOCUS: Edge quality

| | |
|----|---|
| CE | <ul style="list-style-type: none">-Toe pushing-Incorrect blade placement in relation to the long axis-Early three-turn placement-Inability to control entry into back three-turns-Lack of control after the three-turns-Two foot skating after the back pushes-Uneven lobes |
| AD | <ul style="list-style-type: none">-Back three-turns-Maintaining flow-Controlling the check after the turn |
| TE | <ul style="list-style-type: none">-Ability to maintain control of body alignment and fairly good edges-Adhere to a common long axis-Controlled three-turns |

FO-BI Three-Turns in the Field

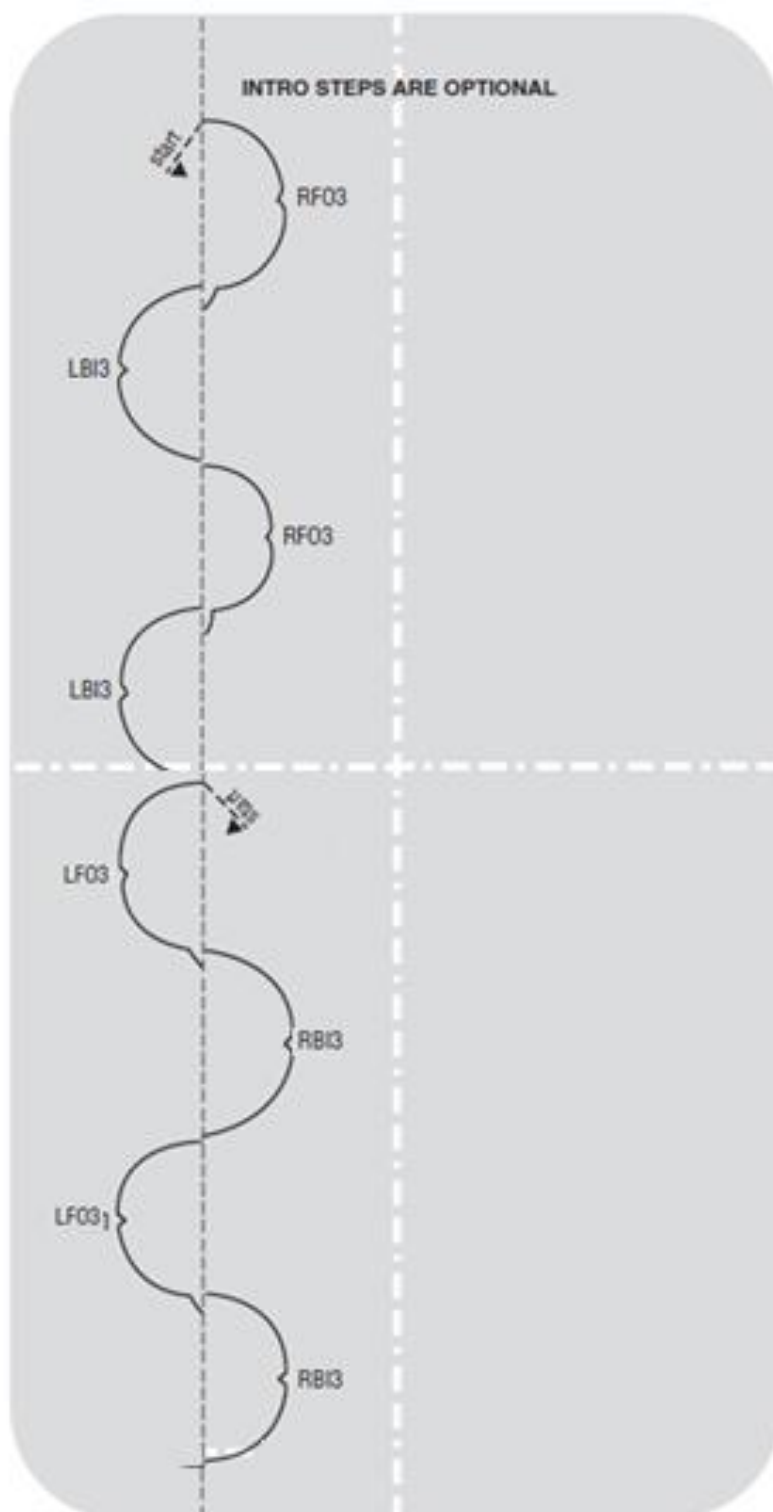

INTER BRONZE (TEST 2) STROKING SKILLS TEST

DESCRIPTION

3. FI-BO three-turns in the field

The skater will perform two sets of forward inside three-turns alternating to backward outside three-turns covering approximately half the length of the rink. One half of the rink will be RFI-LBO three-turns. The skater will perform LFI-RBO three-turns on the other half of the rink. Introductory steps are optional, as are the steps to transition to the second half. This move may start on either foot.

Focus: Edge quality

COMMON ERRORS, AREAS OF DIFFICULTY & TEST EXPECTATIONS

3. FI-BO Three-turns in the field

FOCUS: Edge quality

| | |
|----|---|
| CE | <ul style="list-style-type: none">-Toe pushing-Incorrect blade placement in relation to the long axis-Early three-turn placement-Inability to control entry into back three-turns-Lack of control after the three-turns-Two foot skating after the back pushes-Uneven lobes |
| AD | <ul style="list-style-type: none">-Back three-turns-Maintaining flow-Controlling the check after the turn |
| TE | <ul style="list-style-type: none">-Ability to maintain control of body alignment and fairly good edges-Adhere to a common long axis-Controlled three-turns |

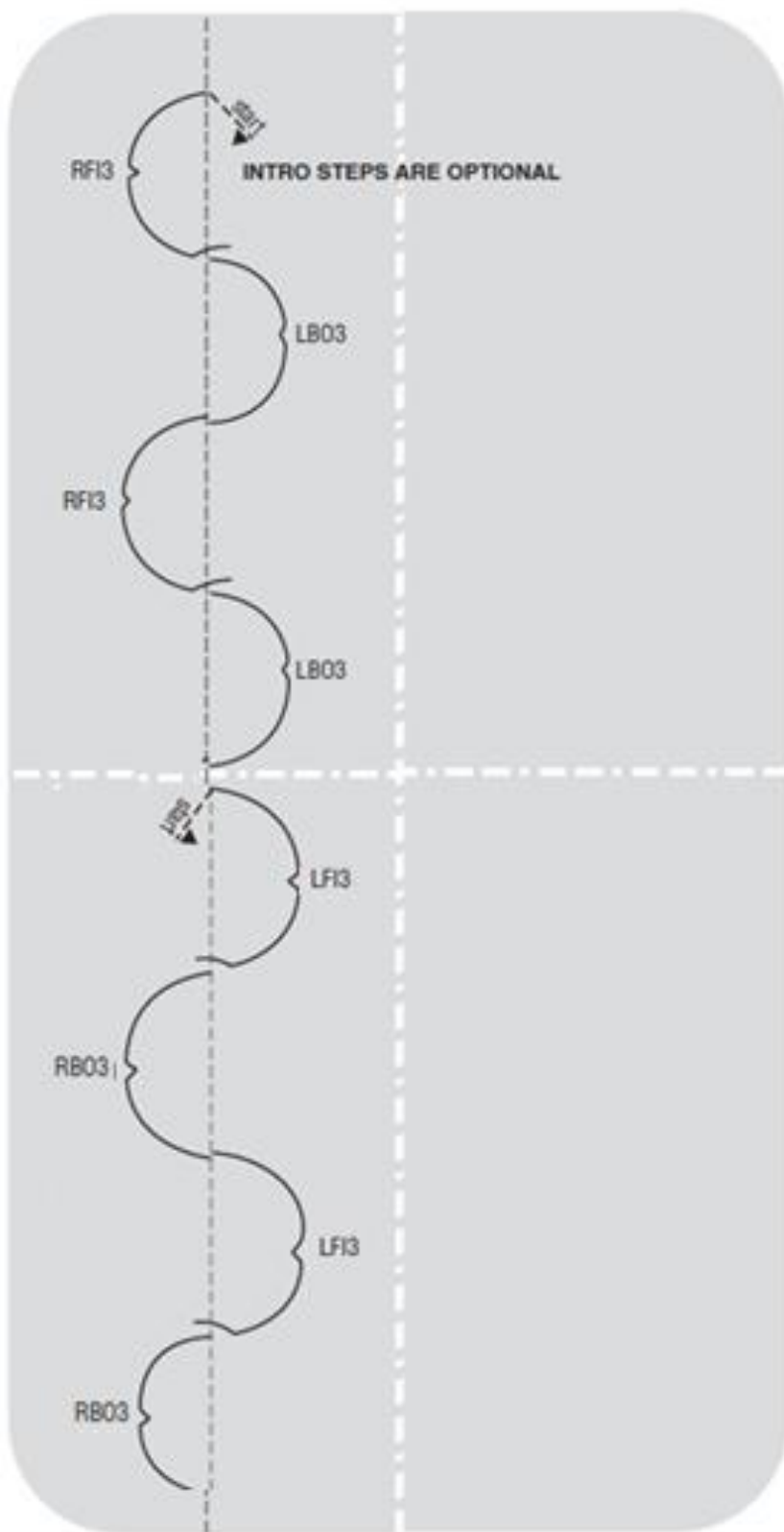

INTER BRONZE (TEST 2) STROKING SKILLS TEST

DESCRIPTION

4. Forward and backward power change of edge pulls

The skater will perform consecutive power change of edge pulls — FIO to FOI — for the full diagonal length of the rink followed by backward change of edge pulls — BOI to BIO — for the second diagonal. The skater will change feet at the centre of the rink. The end sequence and the introductory steps are optional. This move may start on either foot.

Focus: Power

COMMON ERRORS, AREAS OF DIFFICULTY & TEST EXPECTATIONS

4. Forward and backward power change of edge pulls **FOCUS: Power**

| | |
|----|---|
| CE | <ul style="list-style-type: none">-Disguising power with too many introductory steps-Shallow changes-Too much upper body movement-Poor posture-Swinging (wild) free leg |
| AD | <ul style="list-style-type: none">-Forward more difficult than backward-Ability to create power-Correct use of skating knees |
| TE | <ul style="list-style-type: none">-Maintaining or increasing acceleration throughout the element-Hear the 'rip' (the solid sound of edge cutting the ice – edge pressure makes the sound. NOTE: If music is used or the skater is smaller, this sound may be difficult to hear but clear edges will be seen). |

INTER BRONZE (TEST 2) STROKING SKILLS TEST

DESCRIPTION

5. Five-step mohawk sequence

The skater will perform alternating forward inside mohawks, skated in consecutive half circles. Each series consists of a five step sequence. The skater will skate one length of the ice with four or five lobes. Introductory steps are optional.

Focus: Edge quality, extension and quickness.

COMMON ERRORS, AREAS OF DIFFICULTY & TEST EXPECTATIONS

5. Five Step Mohawk Sequence **FOCUS: Edge quality, extension and quickness**

| | |
|----|---|
| CE | <ul style="list-style-type: none">-Incorrect edge on step #4 (FO)-Wide stepping (wider than hip width)-Uneven timing-Poor extension |
| AD | <ul style="list-style-type: none">-Obtaining edge quality and quickness-Ability to create power for correct pattern-Maintaining an even rhythm |
| TE | <ul style="list-style-type: none">-Correct edges (some may be shallower)-Each step should be fairly equal on each lobe-There should be an even rhythm or quickness to the step-Good ice coverage |

5. Five Step Mohawk Sequence FOCUS: Edge quality, extension and quickness

Five Step Mohawk Sequence

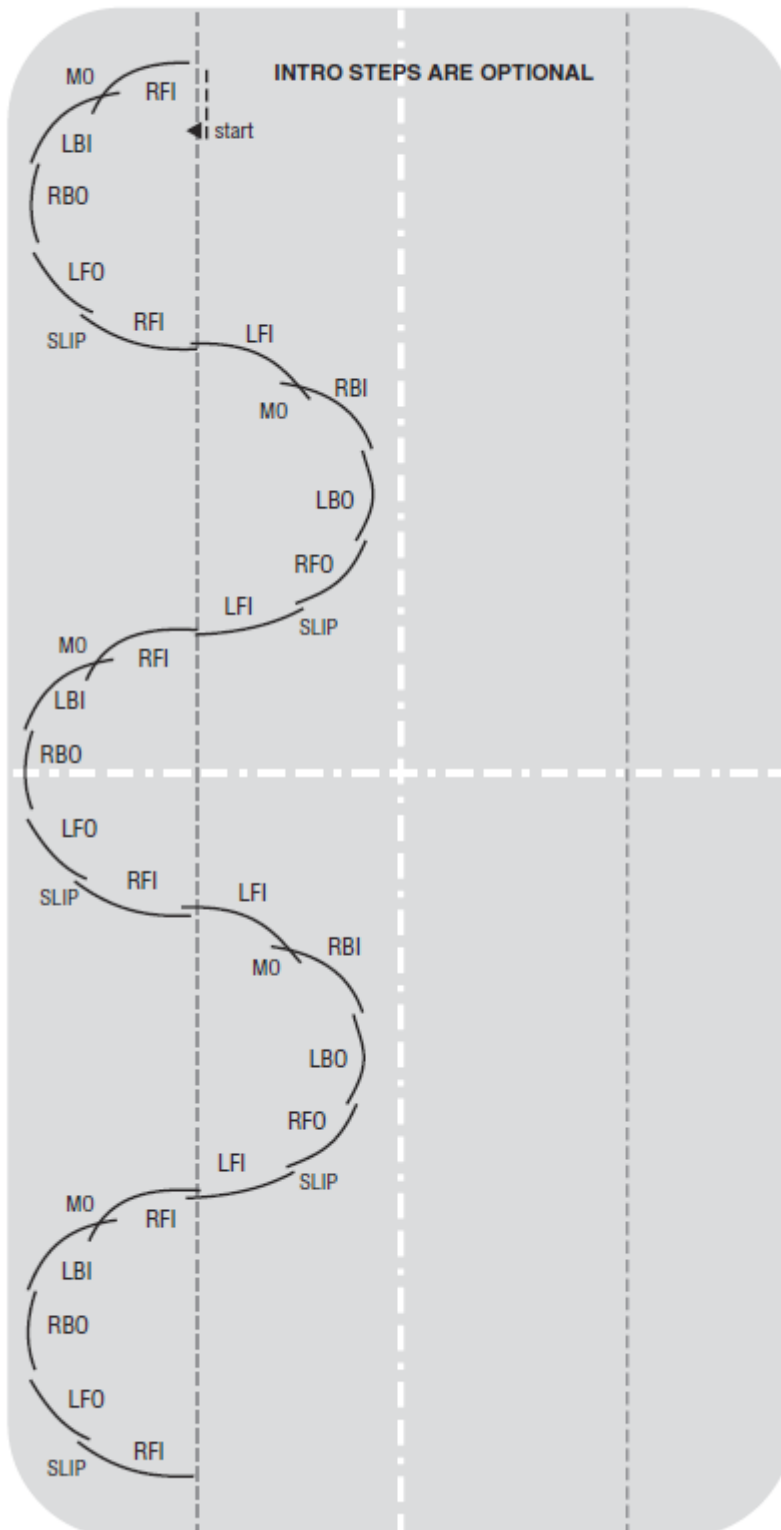

BRONZE (TEST 3) STROKING SKILLS TEST

1. Forward Power Circle
2. Backward Power Circle
3. Eight-step Mohawk Sequence
4. Forward and Backward Free Skating Cross Strokes
5. Backward Power Three-Turns
6. Forward Double Three-Turns

BRONZE (TEST 3) STROKING SKILLS TEST

DESCRIPTION

1. Stroking: Forward power circle

Starting from a standing position, the skater will perform forward crossovers progressively increasing in foot speed and acceleration throughout the entire move, from a slow, but gradually accelerating pace to fully accelerated crossovers. As the skater accelerates, the circle circumference increases. Power circles are performed in both counter-clockwise and clockwise directions. It is recommended that no more than 15 crossovers be utilized in completing each portion of this move. This move may start in either direction.

Focus: Power

COMMON ERRORS, AREAS OF DIFFICULTY & TEST EXPECTATIONS

1. Stroking: Forward Power Circle

FOCUS: Power

| | |
|----|---|
| CE | <ul style="list-style-type: none">-Poor posture-Generally toe pushing on clockwise direction-Inability to increase power-Unequal power from both edges |
| AD | <ul style="list-style-type: none">-Usually clockwise direction-Demonstrating an increase in power-Proper uses of edges to stroke-Control of upper body and posture-Ability to obtain a lilting or consistently soft knee action |
| TE | <ul style="list-style-type: none">-No toe pushing-Noticeable increase in power and circle size-Give credit to skater with 'ripping' sound-Angles of the body will be more acute-Creation of power through a steady progression <p>NOTE: You are not judging the glide after the crossovers but notice the amount of power that has been created.</p> |

Strokng: Forward Power Circle

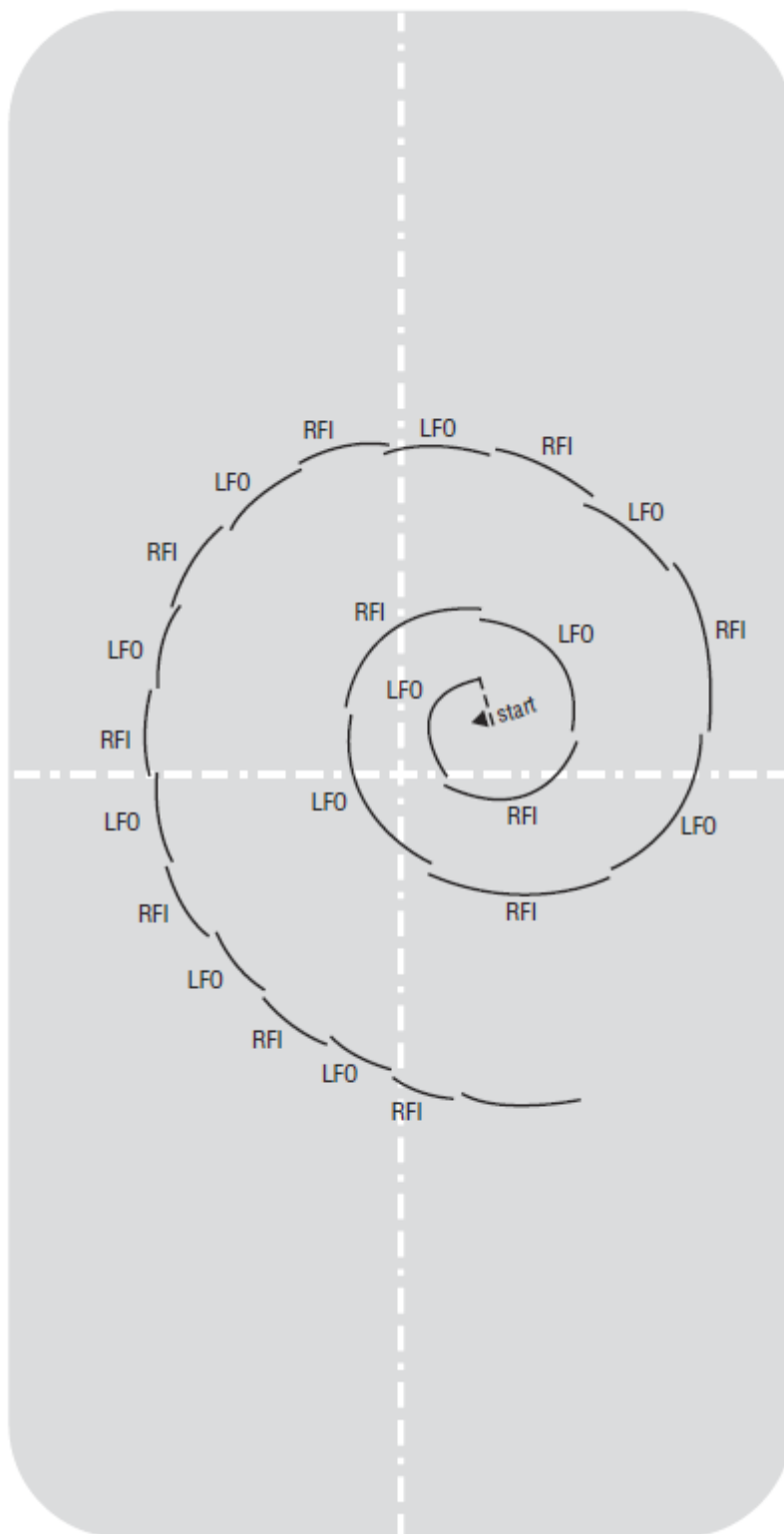

BRONZE (TEST 3) STROKING SKILLS TEST

DESCRIPTION

2. Stroking: Backward power circle

Starting from a standing position, the skater will perform backward crossovers progressively increasing in foot speed and acceleration throughout the entire move, from a slow, but gradually accelerating pace, to fully accelerated crossovers. As the skater accelerates, the circle circumference increases. Power circles are performed in both counter clockwise and clockwise directions. It is recommended that no more than 15 crossovers be utilized in completing each portion of this move. This move may start in either direction.

Focus: Power

COMMON ERRORS, AREAS OF DIFFICULTY & TEST EXPECTATIONS

2. Stroking: Backward Power Circle

FOCUS: Power

| | |
|----|---|
| CE | <ul style="list-style-type: none">-Poor posture-Inability to increase power-Unequal power from both edges |
| AD | <ul style="list-style-type: none">-Usually counterclockwise direction-Demonstrating an increase in power-Proper uses of edges to stroke-Control of upper body and posture-Ability to obtain a lilting or consistently soft knee action |
| TE | <ul style="list-style-type: none">-No toe scratching- Noticeable increase in power and circle size-Angles of the body will be more acute-Creation of power through a steady progression <p>NOTE: You are not judging the glide after the crossovers but notice the amount of power that has been created.</p> |

2. Stroking: Backward Power Circle

FOCUS: Power

Stroking: Backward Power Circle

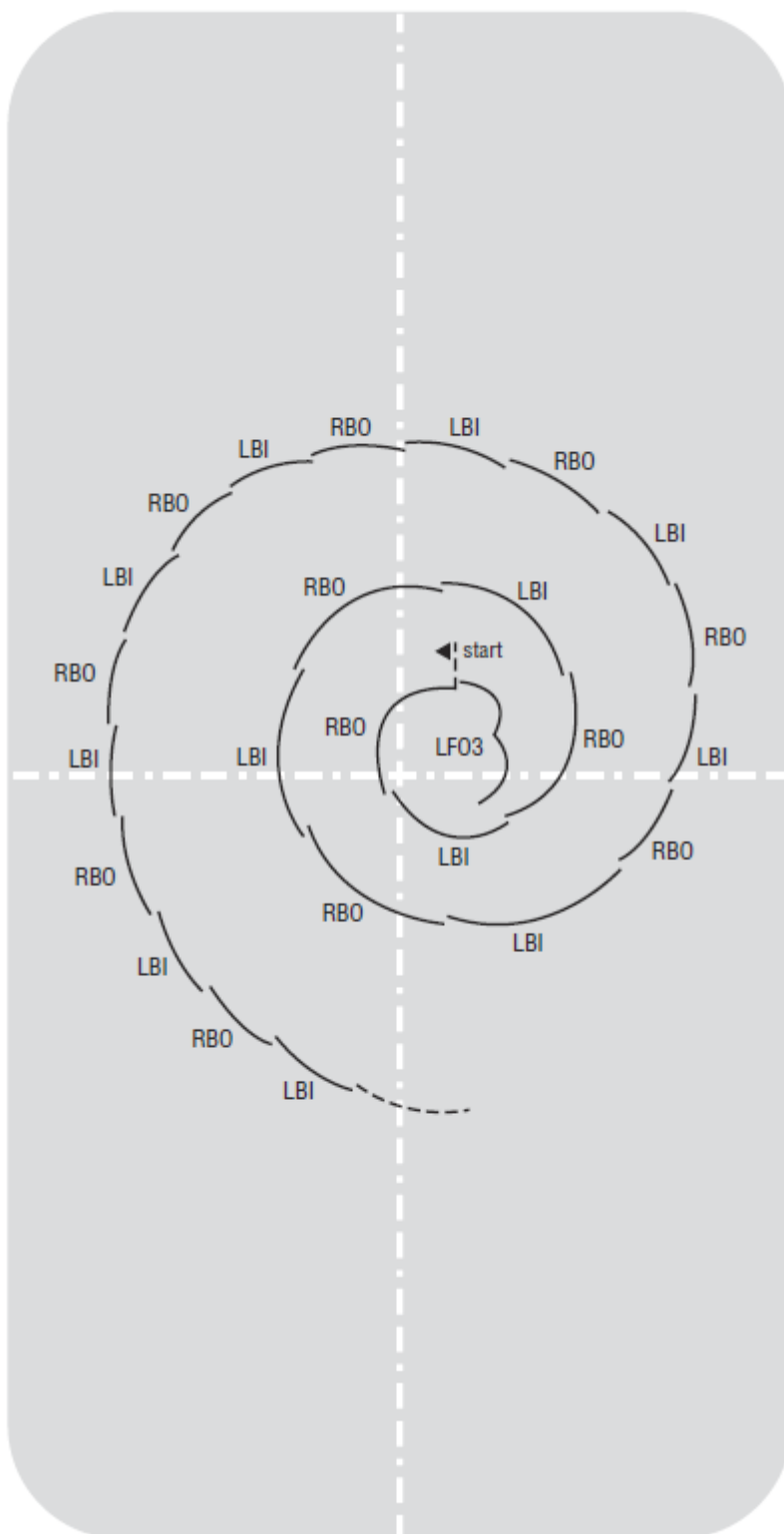

BRONZE (TEST 3) STROKING SKILLS TEST

DESCRIPTION

3. Eight-step mohawk sequence

The skater will perform two eight-step mohawk sequences counter clockwise. The step order is: Forward crossover into a LFO mohawk, followed by LBI, RBO, LBI cross forward and RFI. The skater should maintain a march cadence (one beat per step). Between the circles is a two-beat left foot transition. The sequence is then repeated in the opposite direction. Introductory steps are optional. This move may start on either foot.

Focus: Quickness and power

COMMON ERRORS, AREAS OF DIFFICULTY & TEST EXPECTATIONS

3. Eight step Mohawk Sequence

FOCUS: Quickness and Power

| | |
|----|--|
| CE | <ul style="list-style-type: none">-Circle size too small-Warped circle shape-Uneven timing-Scratchy-Wide stepping (wider than hip width)-Blatant and early change of edge on the mohawk |
| AD | <ul style="list-style-type: none">-Usually clockwise direction-Ability to come back to the centre-Quick rhythm |
| TE | <ul style="list-style-type: none">-Fairly neat placement of footwork-Circle size should be utilising over ½ the width of the rink |

3. Eight step Mohawk Sequence

FOCUS: Quickness and Power

Eight-Step Mohawk Sequence

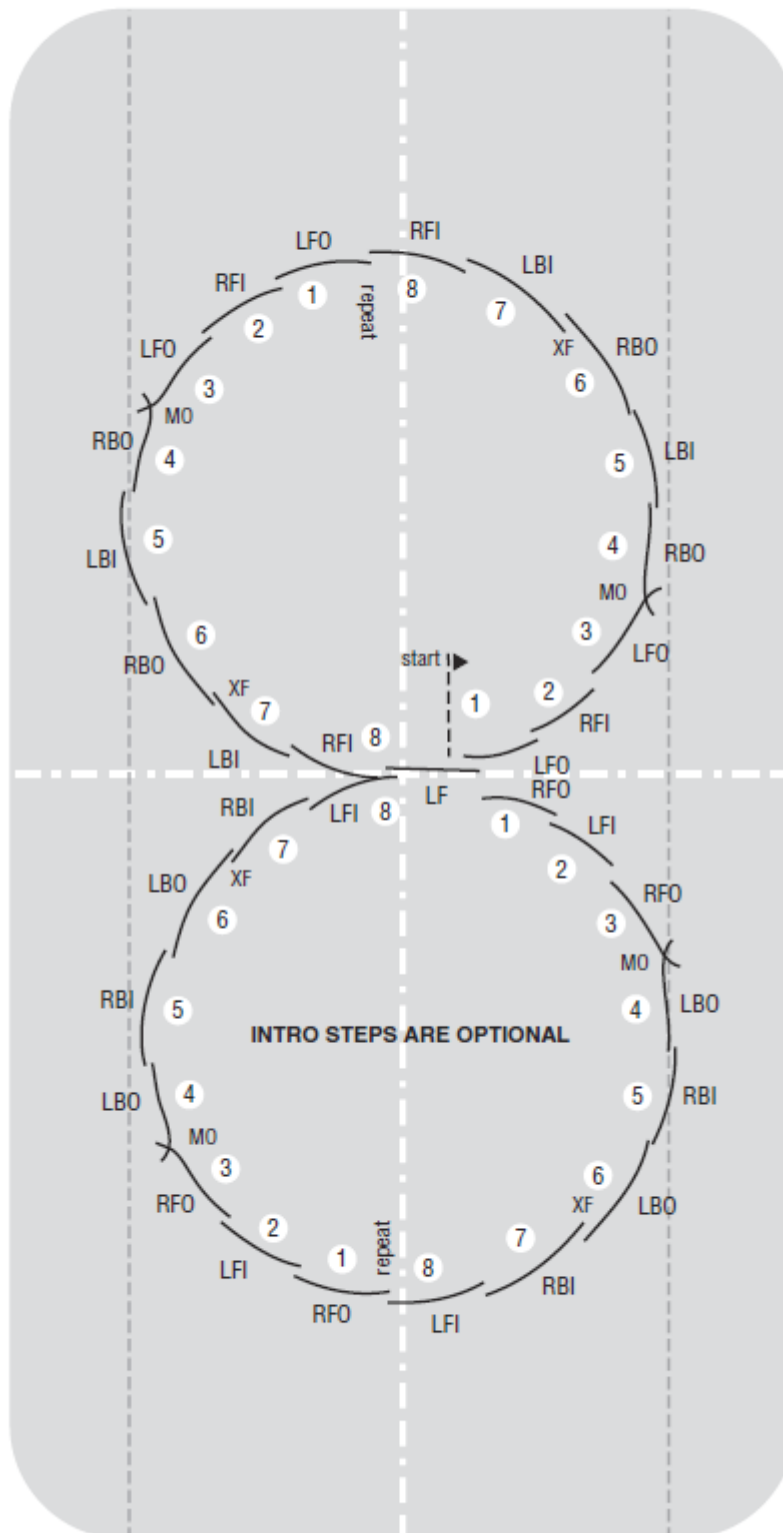

BRONZE (TEST 3) STROKING SKILLS TEST

DESCRIPTION

4. Forward and backward free skate cross strokes

The skater will perform free skate cross strokes the length of the ice surface. Forward cross strokes will be skated for one length of the rink and backward cross strokes skated for the second length of the rink. Introductory steps and end patterns are optional. This move may start on either foot.

Focus: Power

COMMON ERRORS, AREAS OF DIFFICULTY & TEST EXPECTATIONS

4. Forward and Backward Free Skate Cross Strokes

FOCUS: Power

| | |
|----|---|
| CE | <ul style="list-style-type: none">-Toe pushing-Stepping onto toepicks rather than edges on backward-Poor posture-Shallow edges-Poor use of knees-Sloppy free leg |
| AD | <ul style="list-style-type: none">-Ability to create power-Stroking from the outside edge |
| TE | <ul style="list-style-type: none">-Expect slightly shallow edges-Usually forward weaker than backward-Expect no toe pushing-Listen for 'rip' (edge pressure makes the sound)-Cross steps are not acceptable |

BRONZE (TEST 3) STROKING SKILLS TEST

DESCRIPTION

5. Backward power three-turns

The skater will perform three to five backward power three-turns per circle in a figure eight pattern. One complete figure eight is required. A one or two-foot glide may be utilized when changing circles. Introductory steps are optional. This move may start in either direction.

Focus: Power

COMMON ERRORS, AREAS OF DIFFICULTY & TEST EXPECTATIONS

5. Backward Power Three-Turns

FOCUS: Power

| | |
|----|--|
| CE | <ul style="list-style-type: none">-Figure eight size too small-Lack of control after the back three-turn-Balance not held after the three-turn-Turns done too quickly without increase in power-Two foot turns |
| AD | <ul style="list-style-type: none">-Generally clockwise direction (left back three-turns)-Ability to increase power with each turn-Control throughout both directions |
| TE | <ul style="list-style-type: none">-Expect an increase in power with each turn-Both three-turns equal in quality-Turns should be done on one foot-Good control before and after the turns-There should be an even timing throughout-Larger circle indicates more power (give extra credit) |

Backward Power Three-Turns

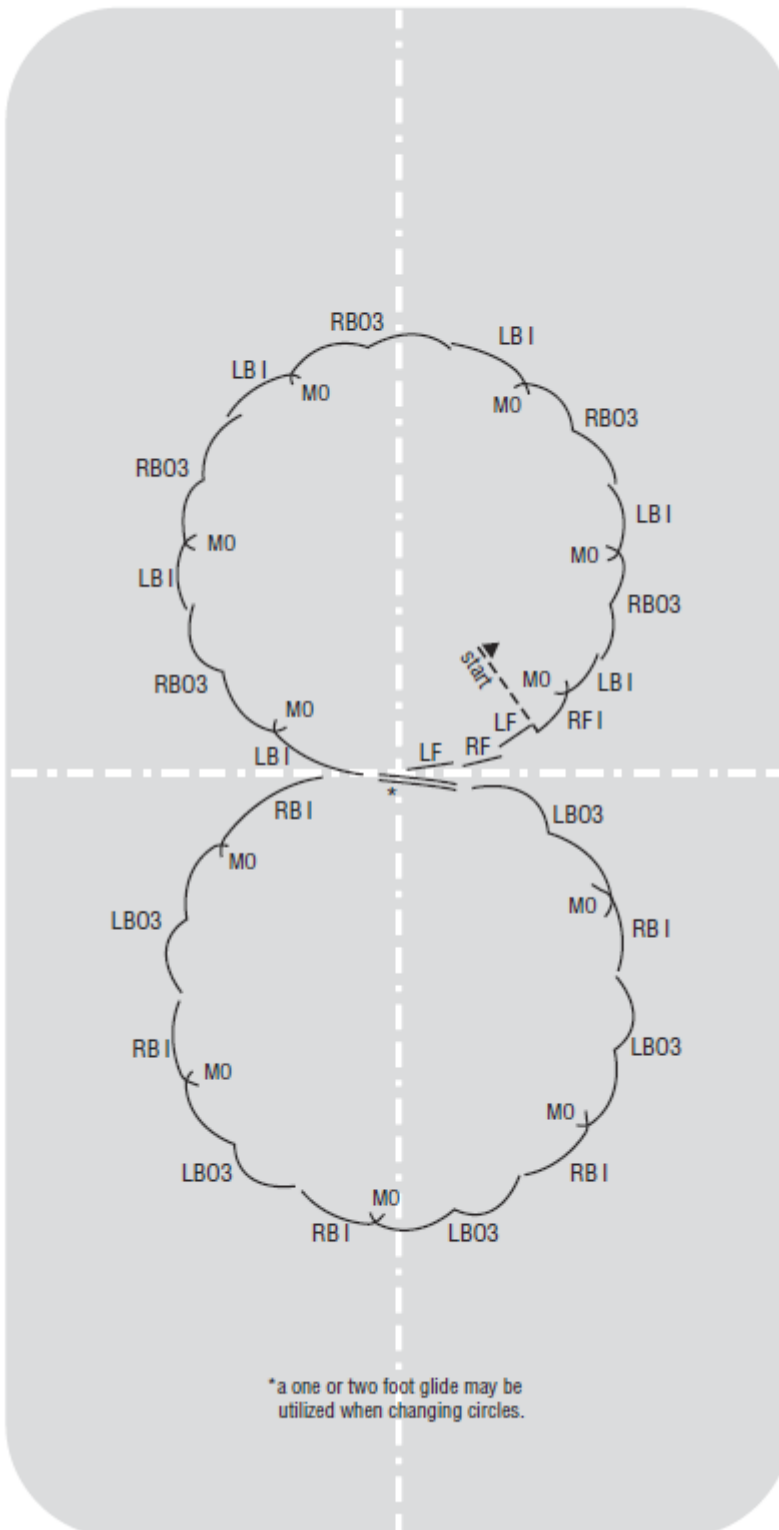

BRONZE (TEST 3) STROKING SKILLS TEST

DESCRIPTION

6. Forward double three-turns

The skater will perform consecutive forward double three-turns on half circles, with alternating of feet. Four to six half circles will be skated depending on the length of the rink and strength of the skater. The sequence begins with FO double three-turns covering the first length of the rink. The FI double three-turns will cover the second length of the rink. Introductory steps and end patterns are optional.

Focus: Edge quality

COMMON ERRORS, AREAS OF DIFFICULTY & TEST EXPECTATIONS

6. Forward Double Three-Turns

FOCUS: Edge quality

| | |
|----|--|
| CE | <ul style="list-style-type: none">-Skated too slow-Subcurves between the two turns-Lack of control after the back three-turn-Poor placement of the turns (too close together)-Toe pushing |
| AD | <ul style="list-style-type: none">-Forward inside double three-turns-Maintaining flow throughout |
| TE | <ul style="list-style-type: none">-Need to see control between the forward turn to the back turn-No subcurves after all turns-No toe pushing-Give additional credit for extended free leg-Give additional credit for good flow and control-Turns should be placed close to the thirds of the lobe |

Forward Double Three-Turns

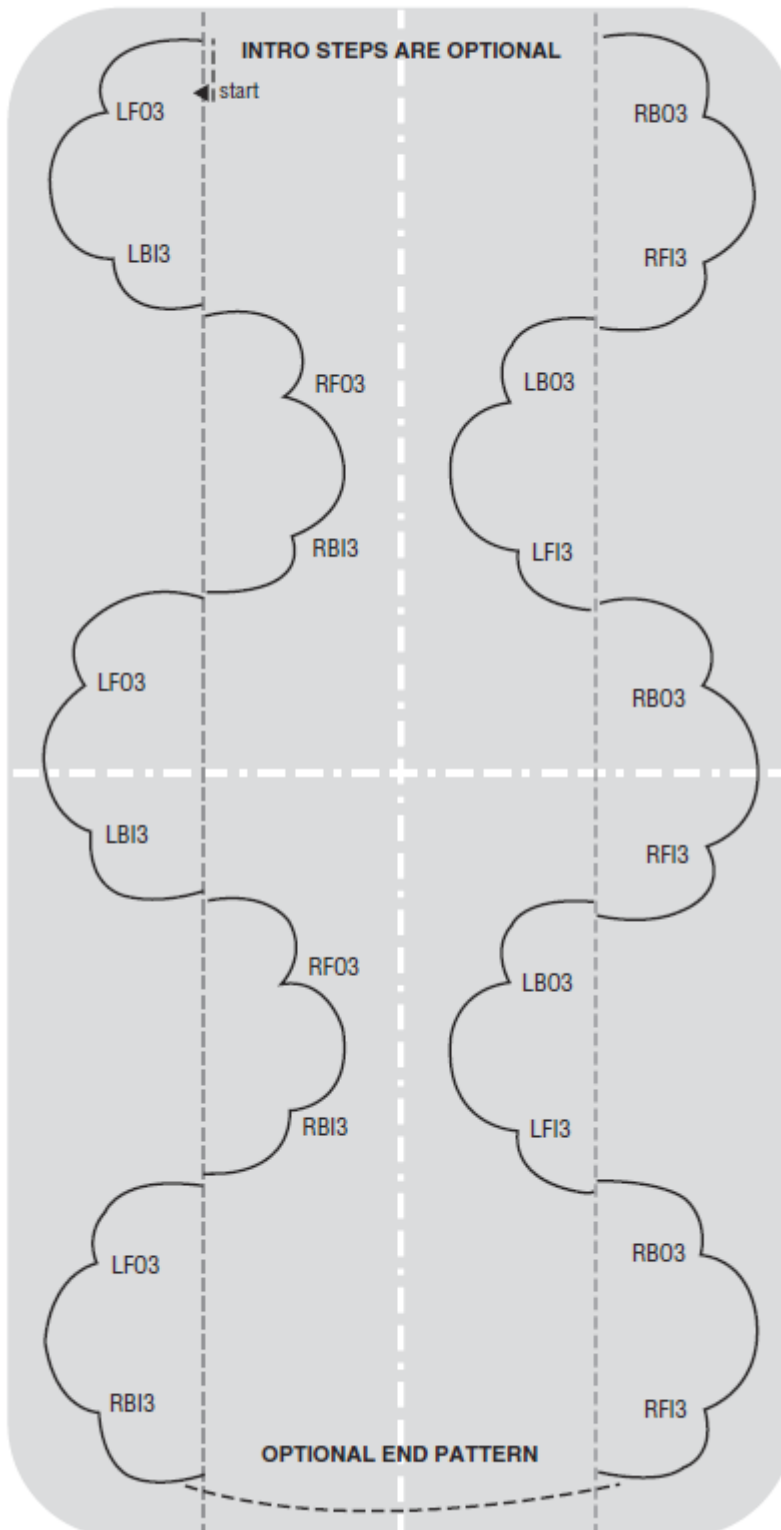

INTER SILVER (TEST 4) STROKING SKILLS TEST

1. Backward Double Three-Turns
2. Spiral Sequence
3. Brackets in the Field Sequence
4. Forward Twizzles
5. Inside Slide Chassé Pattern

INTER SILVER (TEST 4) STROKING SKILLS TEST

DESCRIPTION

1. Backward double three-turns

The skater will perform consecutive backward double three-turns on half circles with alternating feet. Four to six half circles will be skated depending on the length of the rink and strength of the skater. The sequence begins with BO double three-turns covering the first length of the rink. The BI double three-turns will cover the second length of the rink. Introductory steps and end patterns are optional.

Focus: Edge quality and extension

COMMON ERRORS, AREAS OF DIFFICULTY & TEST EXPECTATIONS

1. Backward Double Three-Turns

FOCUS: Edge quality and extension

| | |
|----|---|
| CE | <ul style="list-style-type: none">-Three-turns skated too close together-Lack of control between the turns-Improper turn placement-Lack of flow |
| AD | <ul style="list-style-type: none">-Maintaining flow throughout the move-Total extension during all phases of the move |
| TE | <ul style="list-style-type: none">-Expect good control throughout-Larger pattern indicates an increase in the quality of skating-Give additional credit when skated with an extended free leg-No major subcurves-Back three-turn will be placed at approximately the 1/3 mark and forward three-turn is placed at the 2/3 mark-Should be a controlled gliding edge between the turns |

Backward Double Three-Turns

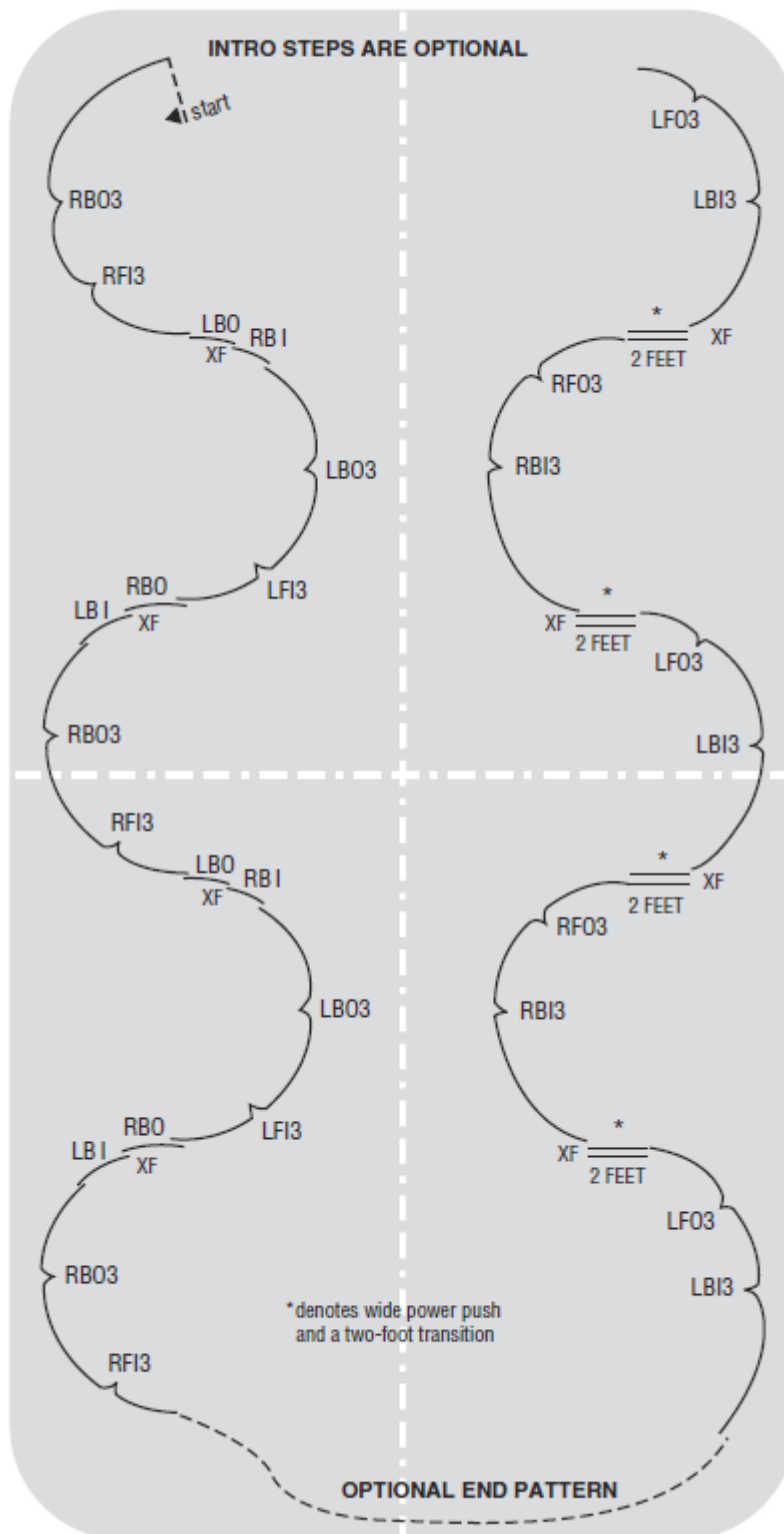

INTER SILVER (TEST 4) STROKING SKILLS TEST

DESCRIPTION

2. Spiral Sequence

The skater will begin with a LFO spiral that should be held until the long axis of the rink. The skater then brings the free leg down into a RFI open mohawk and steps wide with a two-foot power push transition to a backward R over L crossover. The skater will then push into a LBO spiral to be held until the long axis of the rink. Skater must step immediately into a RFI spiral. The free leg will drop into a RFI mohawk and lift again into a LBI spiral, also to be held until the long axis. Optional steps to repeat pattern in opposite direction starting with RFO spiral. Note: all spirals should be sustained with an extended free leg to demonstrate the skater's form and flexibility. Introductory steps are optional. This move may start on either foot.

Focus: Extension and edge quality

COMMON ERRORS, AREAS OF DIFFICULTY & TEST EXPECTATIONS

2. Spiral Sequence

FOCUS: Extension and edge quality

| | |
|----|---|
| CE | <ul style="list-style-type: none">-Poor extension-FI spirals-Maintaining flow throughout-No push onto the BO spiral-Poor edge quality |
| AD | <ul style="list-style-type: none">-Transition from the LBO to the RFI spiral-Transition from the RFI spiral to the LBI spiral-Edge quality |
| TE | <ul style="list-style-type: none">-Good extension and quality line on both legs-Ability to cover the ice surface with flow-No flats or forced edges-Good ice coverage-Basic spiral position with no variations (e.g. holding onto blade or knees, etc.) |

INTER SILVER (TEST 4) STROKING SKILLS TEST

DESCRIPTION

3. Brackets in the field sequence

The skater will perform two sets of turns on half circles (RFO-LBI) down approximately half the length of the rink. Continuing down the remaining length of the rink the skater then will perform two sets of turns (LFO-RBI) with an optional step to transition to the LFO edge. Once completed, the entire sequence is repeated, performing two sets of turns (LFI-RBO) down approximately half the length of the rink. The skater then performs two sets of turns (RFI-LBO) down the remaining length of the rink with an optional step to transition to the RFI edge. Introductory steps are optional. This move may start in either foot; the FO/BI brackets will precede the FI/BO brackets.

Focus: Edge quality

COMMON ERRORS, AREAS OF DIFFICULTY & TEST EXPECTATIONS

3. Brackets in the Field Sequence

FOCUS: Edge quality

| | |
|----|---|
| CE | <ul style="list-style-type: none">-Scraping during the turns-Change of edge before and/or after turn-Turn not on the centre point of lobe-Lack of control during turns-lack of upper body control-Inability to maintain a consistent flow throughout the entire move |
| AD | <ul style="list-style-type: none">-Maintaining a common axis-Edge quality entering and exiting turns |
| TE | <ul style="list-style-type: none">-Give credit when skated with strong, well-controlled edges-Turn will generally be shallow-Move needs to be done on curves with a common axis-Skater should utilise the full length of ice (at least red dot to red dot) |

Brackets in the Field Sequence

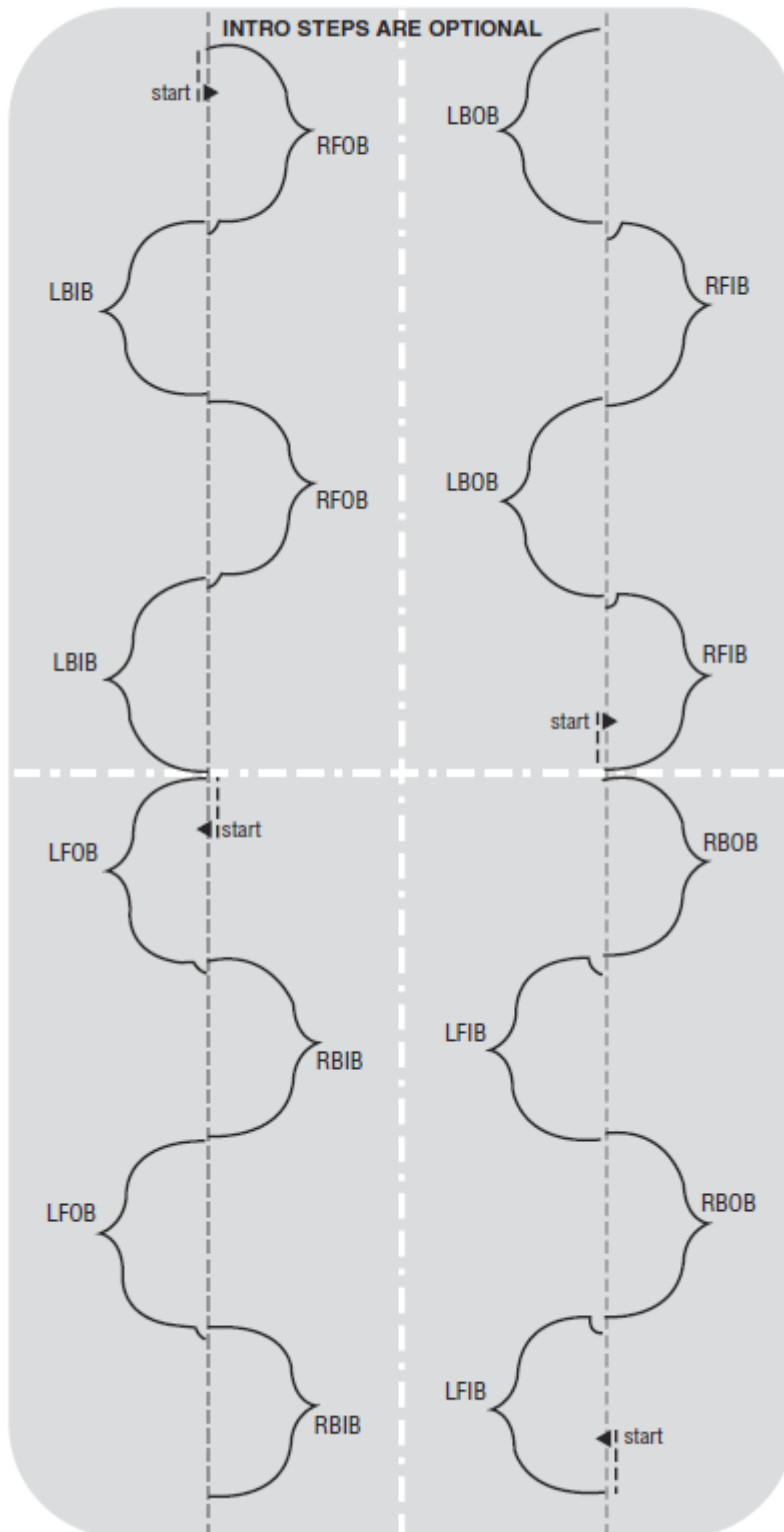

INTER SILVER (TEST 4) STROKING SKILLS TEST

DESCRIPTION

4. Forward twizzles

Forward outside twizzles: The skater will begin from a standing start with a LFO roll, forward cross stroke to a RFO twizzle which ends on RBI after 1 & 1/2 revolutions. The skater will then step LFO to complete the set. Three twizzle sets are to be repeated across the width or down the length of the rink and they should be repeated on the opposite foot in the same manner. Forward inside twizzles: For the second part of the move, the skater will begin from a standing start with a LFI roll to a RFI twizzle which ends on RBO after 1 & 1/2 revolutions. The skater will then step LFI to complete the set. Three twizzle sets are to be repeated across the width or down the length of the rink and they should be repeated on the opposite foot in the same manner. This move may start in either direction.

Focus: Turn execution and continuous flow

COMMON ERRORS, AREAS OF DIFFICULTY & TEST EXPECTATIONS

4. Forward Twizzles

FOCUS: Turn execution and continuous flow

| | |
|----|--|
| CE | <ul style="list-style-type: none">-Spinning or 'checked' three-turn motion-Lack of control during twizzles-Lack of upper body control-Wild arms-Inability to maintain a consistent flow throughout the entire move |
| AD | <ul style="list-style-type: none">-Control after the twizzle-Returning to a common axis |
| TE | <ul style="list-style-type: none">-Correct twizzle action-No two foot turns-Good posture and body alignment-Beginning edge should be initiated as close to perpendicular to the axis as possible |

Forward Twizzles

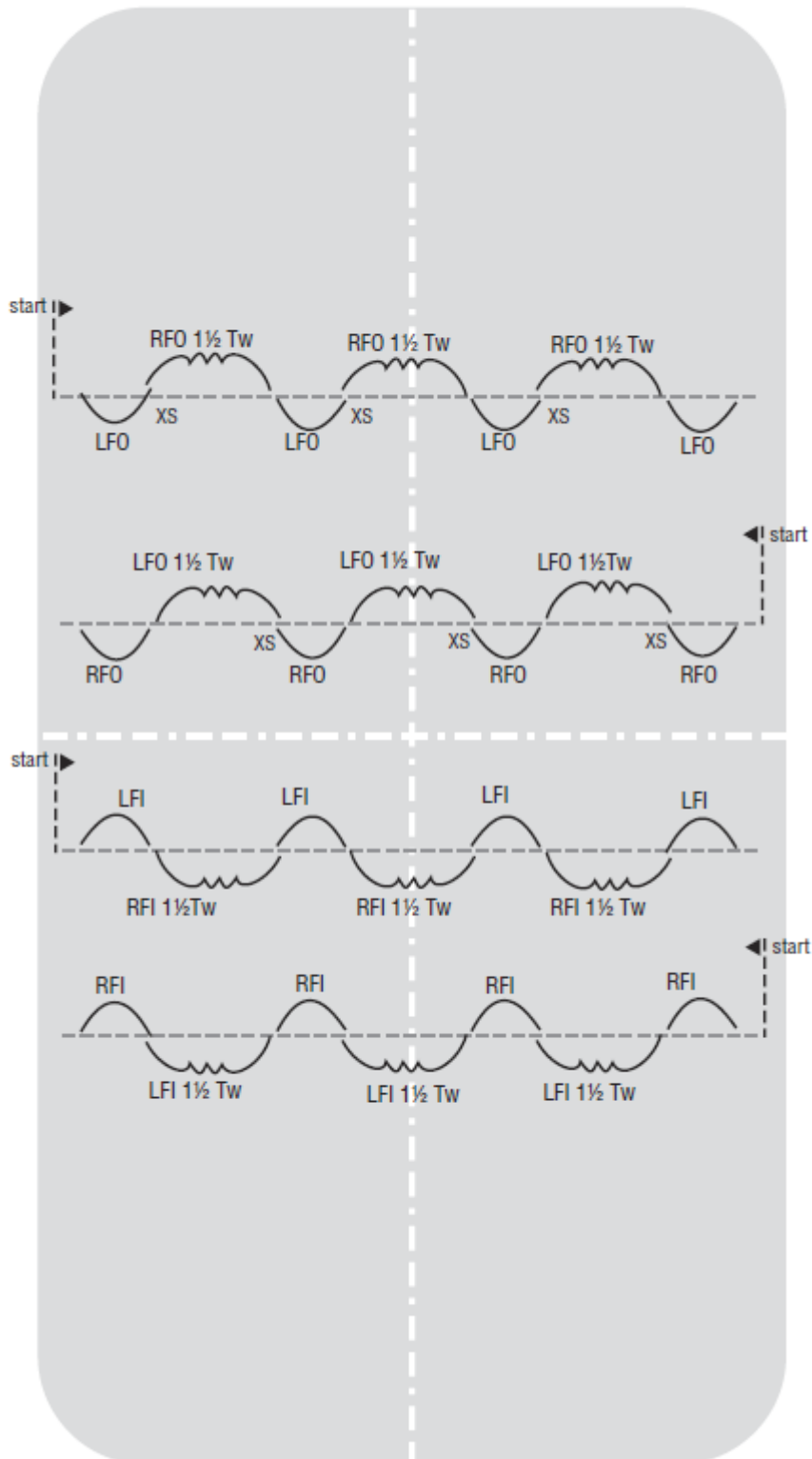

INTER SILVER (TEST 4) STROKING SKILLS TEST

DESCRIPTION

5. Inside slide chassé pattern

The skater will perform four alternating patterns of inside slide Chassés preceded by backward power three-turns. The pattern should cover the entire length of the rink. Introductory steps are optional.

Focus: Edge quality and extension

COMMON ERRORS, AREAS OF DIFFICULTY & TEST EXPECTATIONS

5. Inside Slide Chassé Pattern

FOCUS: Edge quality and extension

| | |
|----|--|
| CE | <ul style="list-style-type: none">-Lack of control after the back turn-Lobes too small due to lack of power-Shallow FI edges during the slide chassés-Poor extension-Toe pushing |
| AD | <ul style="list-style-type: none">-Correct pattern |
| TE | <ul style="list-style-type: none">-Give credit for increased ice coverage (indicates better edge quality and power)-Listen for 'rip' during slide chassés-Even flow throughout-Good posture and body alignment-No two foot turns-Expect a nice rhythm to the step |

SILVER (TEST 5) STROKING SKILLS TEST

1. Inside Three-Turns / Rocker Choctaws
2. Forward and Backward Outside Counters
3. Forward and Backward Inside Counters
4. Forward Loops
5. Backward Swing Rocker Sequence
6. Backward Twizzles

SILVER (TEST 5) STROKING SKILLS TEST

DESCRIPTION

1. Inside three-turns/rocker choctaws

The move should be skated across four semi-circles down the long axis of the rink. The first two lobes consist of FI and BI three-turns and the second half of the move will consist of rocker/choctaw sequences. Four to five 'sets' of each turn per lobe are recommended. The skater will begin with RFI3-LBI3 sets repeated four to five times (depending on rink size). After the last LBI3 the skater should step RFI and begin the second lobe with a LFI3-RBI3 set and repeat in the same manner. To transition to the rocker/choctaw sequences, the skater should perform LFI mohawk and change edge to RBO crossing in front. The third lobe begins with a LBI rocker/LFI closed choctaw set repeated four to five times (depending on rink size). After the last choctaw and cross front, the skater should step RFI and perform a RFI mohawk and change edge to LBO cross forward. The fourth lobe consists of RBI rocker/RFI closed choctaw sets repeated four to five times. Introductory steps are optional. This move may start in either direction.

Focus: Power and quickness

COMMON ERRORS, AREAS OF DIFFICULTY & TEST EXPECTATIONS

1. Inside three-turns/rocker choctaws

FOCUS: Power and Quickness

| | |
|----|---|
| CE | <ul style="list-style-type: none">-Scratchy-Too bouncy-Breaking at the waist throughout the drop three section-Not quick enough on the three-turns-Decrease in power during back rockers-Lack of quickness-Sloppy free legs |
| AD | <ul style="list-style-type: none">-Generally clockwise direction-Stroking from the blade for FI three-turns-Correct pattern and/or complete ice coverage-Maintaining quickness and power on back rockers-Executing required choctaw |
| TE | <ul style="list-style-type: none">-Maintain or increase power throughout-Fairly quiet-Level upper body carriage-Good posture-Consistent flow-Both directions of equal quality-Good ice coverage-Tidy feet |

SILVER (TEST 5) STROKING SKILLS TEST

DESCRIPTION

2. Forward and backward outside counters

The skater will perform forward outside counters followed by two backward free skating cross strokes to a backward outside counter. Each backward counter is then followed by two forward free skating cross strokes to a forward outside counter. The skater has the option of starting the first length with either the right or left forward counter. The second length will be performed with forward and backward outside counters on the opposite foot. The introductory steps and complete loop are optional.

Focus: Edge quality and power

COMMON ERRORS, AREAS OF DIFFICULTY & TEST EXPECTATIONS

2. Forward and backward outside counters

FOCUS: Edge quality and Power

| | |
|----|---|
| CE | <ul style="list-style-type: none">-Skated too slowly-Lack of control after the counter-Use of toe picks during the connecting steps-Lack of rhythm/flow during the connecting steps-Improper use of edges-Obvious or blatant change of edge before the turn-Diagonal pattern of turn across axis line |
| AD | <ul style="list-style-type: none">-Cross strokes or connecting steps-Back counters-Cross strokes after the first back turn |
| TE | <ul style="list-style-type: none">-No obvious or blatant change of edge before the counter turn-Give additional credit when skated with speed-Give additional credit when optional circle is held-Good knee rhythm-Good upper body carriage-Posture and line should be very good-Look for counter body action, not counter turn-Turns and connecting steps should be close to the axis |

Forward & Backward Outside Counters

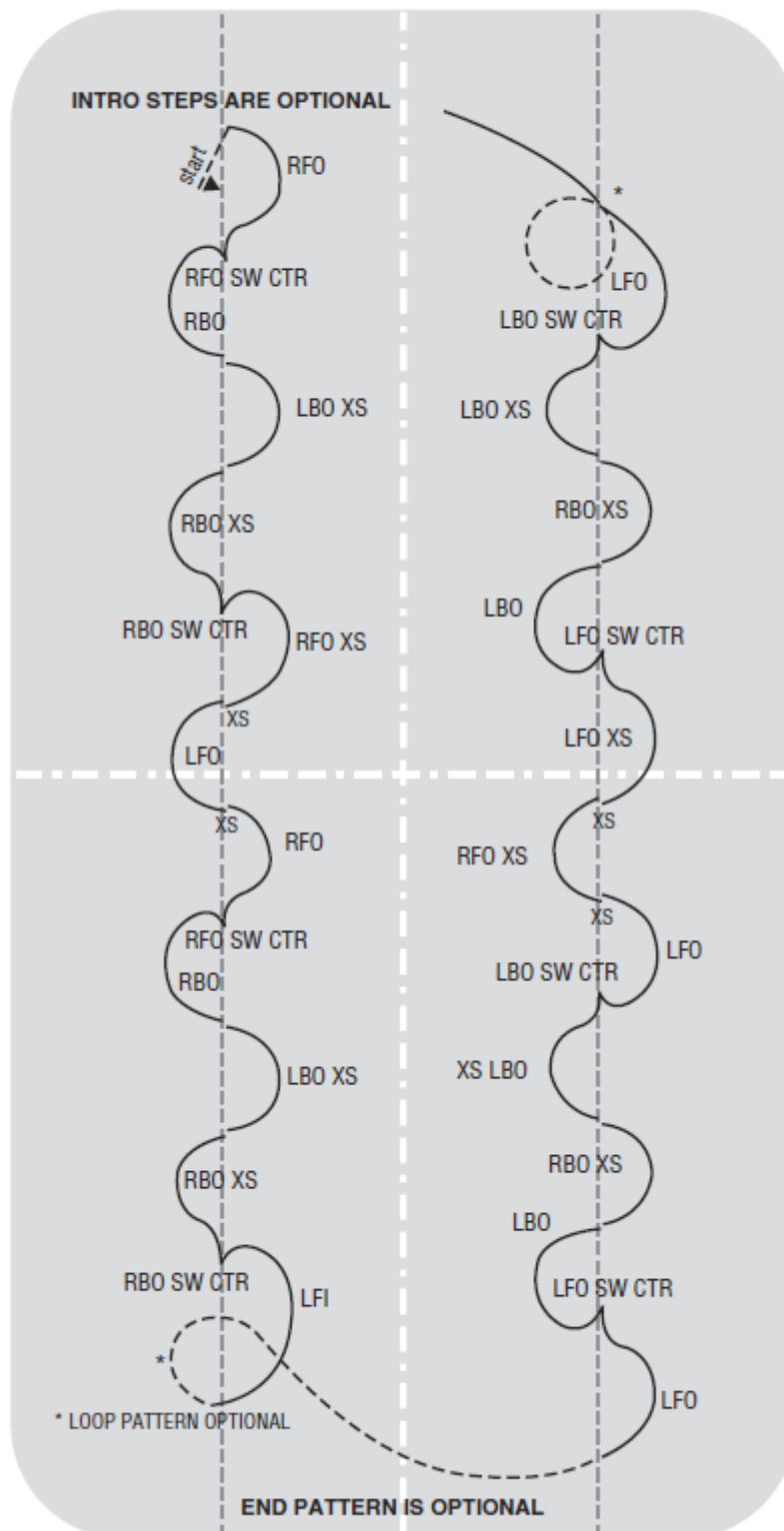

SILVER (TEST 5) STROKING SKILLS TEST

DESCRIPTION

3. Forward and backward inside counters

The skater will perform forward inside counters followed by two backward inside rolls to a backward inside counter. Each backward inside counter is then followed by two forward inside rolls to a forward inside counter. The skater has the option of starting the first length with either the right or left forward counter. The second length will be performed with forward and backward inside counters on the opposite foot. The introductory steps and the end patterns are optional.

Focus: Edge quality and power

COMMON ERRORS, AREAS OF DIFFICULTY & TEST EXPECTATIONS

3. Forward and backward inside counters FOCUS: Edge quality and Power

| | |
|----|---|
| CE | <ul style="list-style-type: none">-Skated too slowly-Toe pushing-Lack of edge quality during connecting steps-Obvious or blatant change of edge before the turn-Diagonal pattern of turn across axis line |
| AD | <ul style="list-style-type: none">-Control after the counters-Connecting steps-Restart after the first back counter-Flow or rhythm of entire sequence |
| TE | <ul style="list-style-type: none">-No obvious or blatant change of edge before the counter turn-Give additional credit when skated with speed-Expect slower rhythm than the outside counters-Good knee rhythm-Good upper body carriage-Turns will be more perpendicular to the axis than the outside turns-Look for counter body action, not counter turn-Turns and connecting steps should be close to the axis |

Forward & Backward Inside Counters

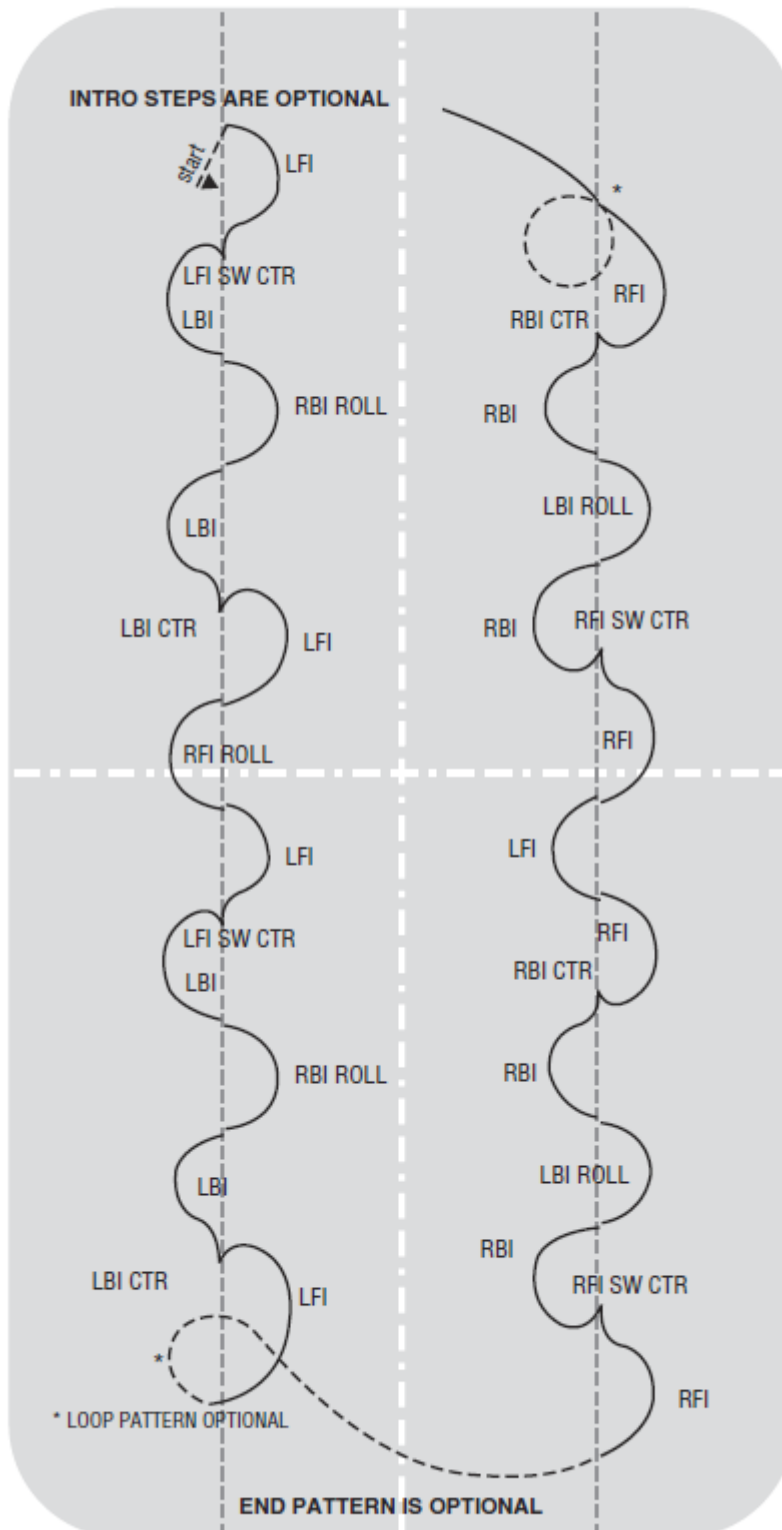

SILVER (TEST 5) STROKING SKILLS TEST

DESCRIPTION

4. Forward loops

The move may be skated across the width or down the length of the rink and begins from a standing start. The skater will begin with a LFO swing roll to prepare for the first RFO loop. The skater then pushes into a LFO loop when returning to the axis. This is repeated twice. After the last LFO loop the skater should perform a RFI chassé to prepare for a LFI loop. This loop is followed by a push into a RFI loop. These loops are also repeated twice to complete the move. This move may start on either foot. **Focus: Edge quality and continuous flow**

COMMON ERRORS, AREAS OF DIFFICULTY & TEST EXPECTATIONS

4. Forward loops

FOCUS: Edge quality and continuous flow

| | |
|----|---|
| CE | <ul style="list-style-type: none">-Creates a rounded rather than elongated loop-Lack of control after loop-Lack of upper body control-Two footing on loops-Inability to maintain a consistent flow throughout the entire move |
| AD | <ul style="list-style-type: none">-Control after the loop-Returning to a common axis-No retrogression after loop |
| TE | <ul style="list-style-type: none">-Correct loop action-No touching down with free foot-Good posture and body alignment-Beginning edge should be initiated as close to perpendicular to the axis as possible |

Forward Loops

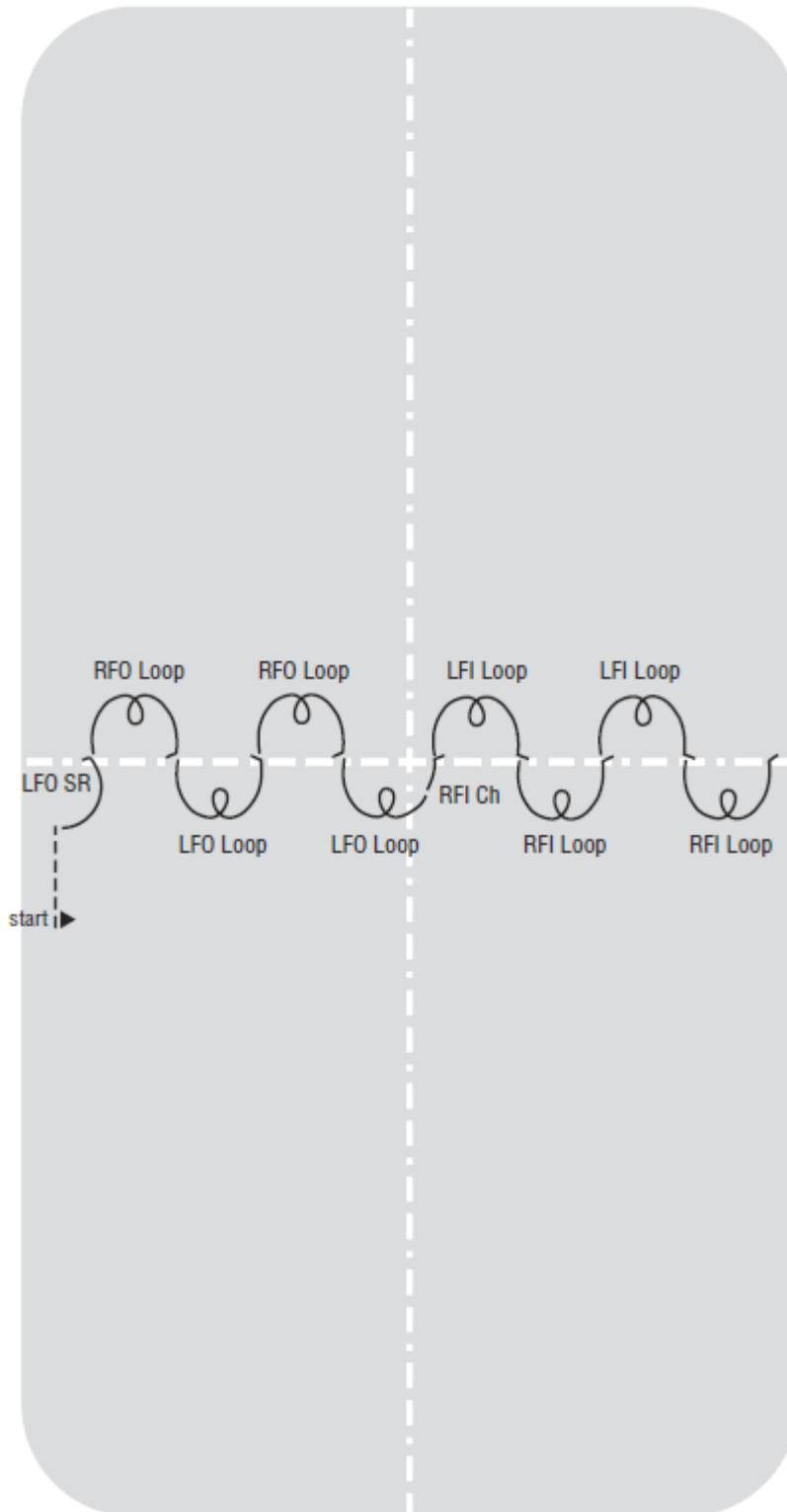

SILVER (TEST 5) STROKING SKILLS TEST

DESCRIPTION

5. Backward rocker choctaw sequence

The skater will perform a backward inside rocker-choctaw followed by a deep backward outside edge. This sequence is performed in six to eight consecutive half circles on alternating feet. The introductory steps are optional. This move may start on either foot.

Focus: Edge quality, extension and power

COMMON ERRORS, AREAS OF DIFFICULTY & TEST EXPECTATIONS

5. Backward rocker choctaw sequence

FOCUS: Edge quality, extension and power

| | |
|----|---|
| CE | <ul style="list-style-type: none">-Inability to maintain or increase power-Lack of edge quality-Choppy steps-Lack of quality choctaws-Poor extension and body line-Loss of control after the choctaw |
| AD | <ul style="list-style-type: none">-Extension during the entire move-Maintaining flow throughout the entire move-Checking the choctaw-Using the choctaw to increase power |
| TE | <ul style="list-style-type: none">-Maintaining power-Equal power on both sides-Good extension (optional free leg)-Good upper body carriage |

5. Backward rocker choctaw sequence

FOCUS: Edge quality, extension and power

Backward Rocker Choctaw Sequence

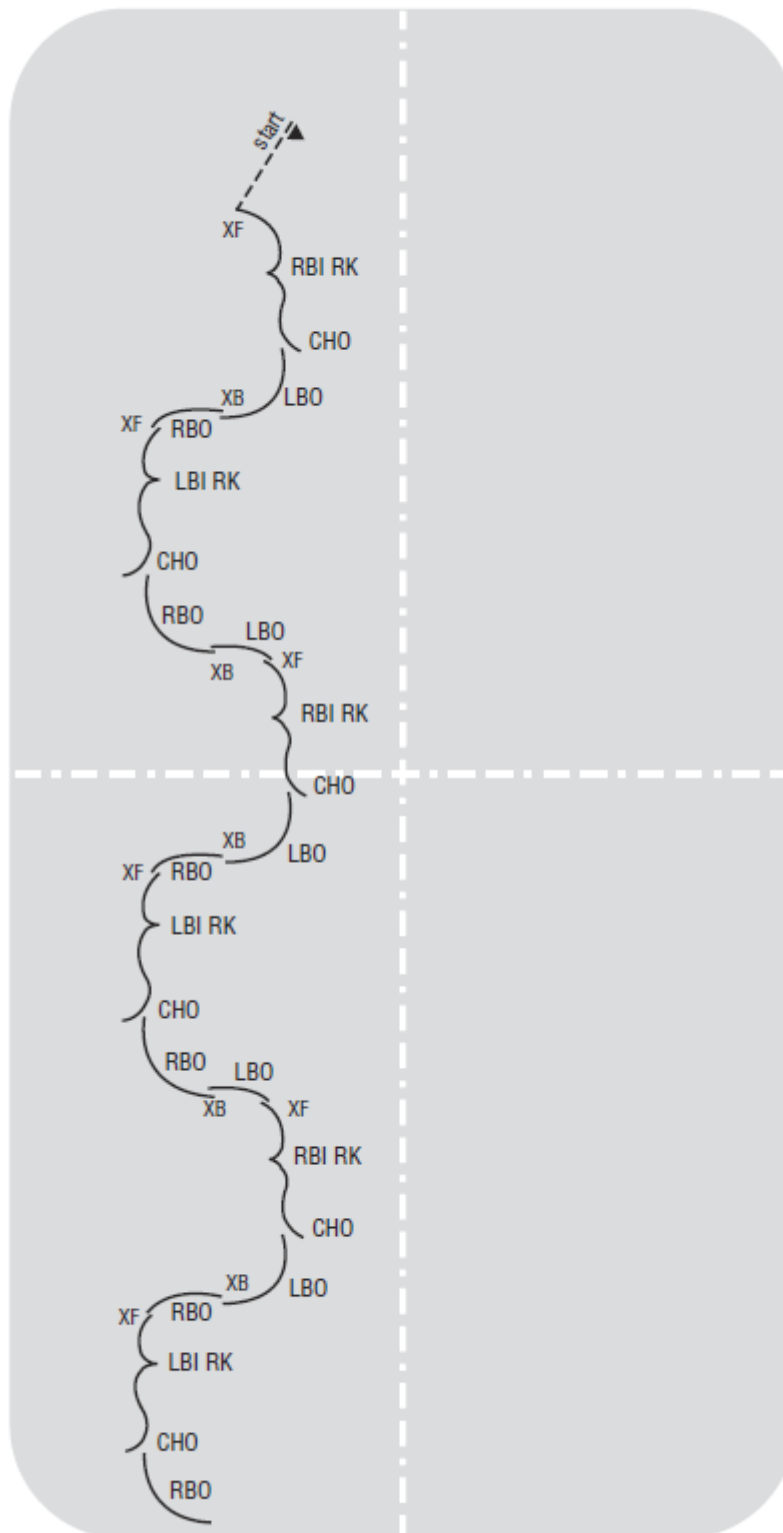

SILVER (TEST 5) STROKING SKILLS TEST

DESCRIPTION

6. Backward twizzles

Backward outside twizzles: The skater will begin with a LFO three-turn changing edge into a LBO double twizzle with a two-foot push to assist the twizzle rotation. The skater then steps forward into a RFO three-turn, changing edge into a RBO double twizzle, completing a 'twizzle set'. Each 'twizzle set' is performed three times down the length of the rink. BI Twizzles: The second part of the move begins with a RFI mohawk whose exit edge is the entry for a LBI double twizzle. The skater then steps on a RFI edge into a LFI mohawk whose exit edge is the entry for a RBI double twizzle, completing a 'twizzle set'. Each set is performed three times down the length of the rink. This move may start in either direction. Introductory steps and end pattern are optional.

Focus: Turn execution and continuous flow.

COMMON ERRORS, AREAS OF DIFFICULTY & TEST EXPECTATIONS

6. Backward twizzles

FOCUS: Turn execution and continuous flow

| | |
|----|--|
| CE | <ul style="list-style-type: none">-Spinning or 'checked' three-turn motion-Lack of control during twizzles-Lack of upper body control-Wild arms-Inability to maintain a consistent flow throughout the entire move |
| AD | <ul style="list-style-type: none">-Control after the twizzle-Returning to a common axis-Forward inside edge after the inside twizzle |
| TE | <ul style="list-style-type: none">-Correct twizzle action-No two foot turns-Good posture and body alignment-Beginning edge should be initiated as close to perpendicular to the axis as possible |

Backward Twizzles

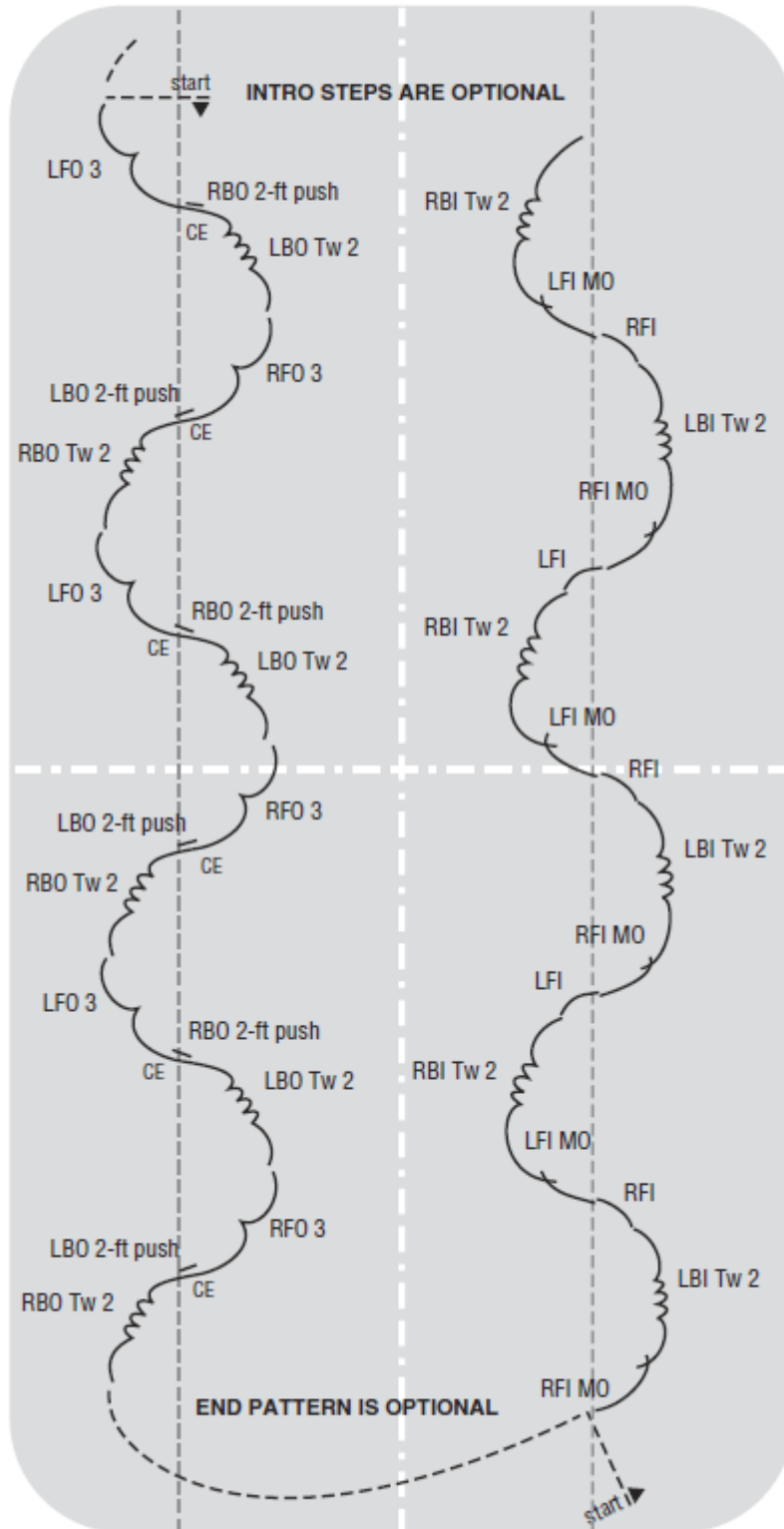

INTER GOLD (TEST 6) STROKING SKILLS TEST

1. Forward and Backward Outside Rockers
2. Forward and Backward Inside Rockers
3. Power Pulls
4. Choctaw Sequence
5. Backward Loop Pattern
6. Straightline Step Sequence

INTER GOLD (TEST 6) STROKING SKILLS TEST

DESCRIPTION

1. Forward and backward outside rockers

The skater will perform FO rockers followed by two backward cross strokes to a BO rocker. This BO rocker is followed by two FO cross strokes to a FO rocker. The skater has the option of starting the first length with either the right or left forward rockers. The second length will be performed with the FO BO rockers on the opposite foot. There should be two forward and two backward rockers. Note: This move may start in either direction. The introductory steps and end sequence of steps are optional.

Focus: Edge quality and power

COMMON ERRORS, AREAS OF DIFFICULTY & TEST EXPECTATIONS

1. Forward and backward outside rockers

FOCUS: Edge quality and power

| | |
|----|---|
| CE | <ul style="list-style-type: none">-Skated too slow-Decrease in flow-Slight toe pushing during connecting steps-Poor edge quality-Three-turns instead of rockers-Poor check on forward turn-Incorrect connecting steps |
| AD | <ul style="list-style-type: none">-Control after the rockers-Connecting steps after the forward turn-Cross strokes after the first back rocker-Forward swing rocker-Maintaining good posture |
| TE | <ul style="list-style-type: none">-Give additional credit when skated with speed-The more speed may cause the rockers to be slightly diagonal-Give additional credit when optional circle is held-Look for overall rocker action-Excellent rhythmic or 'lilting' knee action-Excellent free leg control-Must cross in front after the forward rocker-Posture should be excellent |

Forward & Backward Outside Rockers

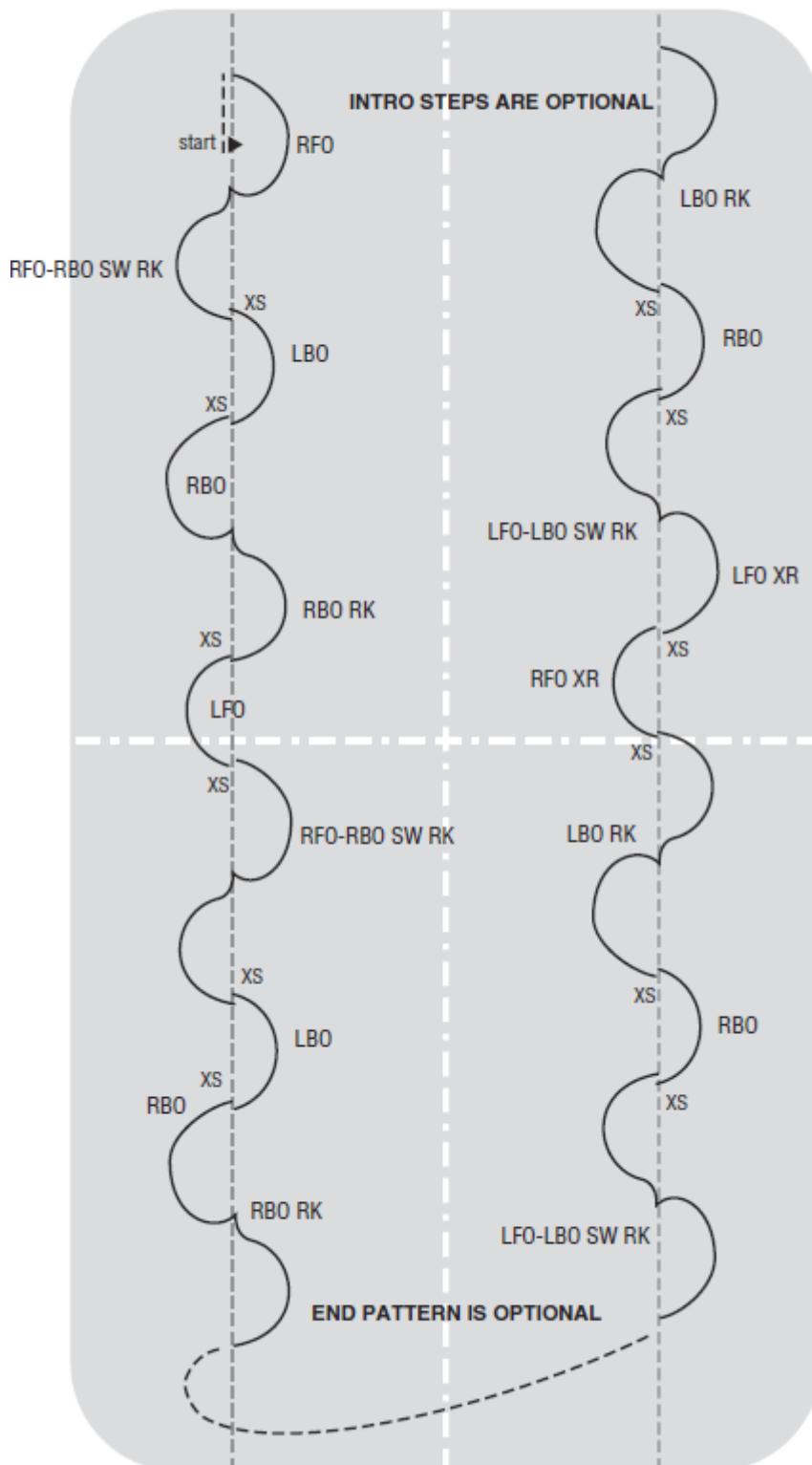

INTER GOLD (TEST 6) STROKING SKILLS TEST

DESCRIPTION

2. Forward and backward inside rockers

The skater will perform forward inside rockers followed by backward inside rolls to a backward inside rocker. This backward inside rocker is followed by forward inside rolls to a forward inside rocker for the length of the rink. The skater has the option of starting the first length with either the right or left forward rockers. The second length will be performed with the forward and backward inside rockers on the opposite foot. There should be two forward and two backward rockers. The introductory steps and end sequence of steps are optional.

Focus: Edge quality and power

COMMON ERRORS, AREAS OF DIFFICULTY & TEST EXPECTATIONS

2. Forward and backward inside rockers

FOCUS: Edge quality and power

| | |
|----|--|
| CE | <ul style="list-style-type: none">-Skated too slow-Decrease in flow-Poor connecting steps-Inability to obtain quickness-Three-turns instead of rockers |
| AD | <ul style="list-style-type: none">-Control after the rockers-Creating and maintaining power and good edge quality through connecting steps-Difficult restart after the first back rocker |
| TE | <ul style="list-style-type: none">-Give additional credit when skated with speed-Turns will be more perpendicular to the axis than the outside turns-Give additional credit when optional circle is held-Excellent rhythmic or 'lilting' knee action-Excellent free leg control-Posture should be excellent |

Forward & Backward Inside Rockers

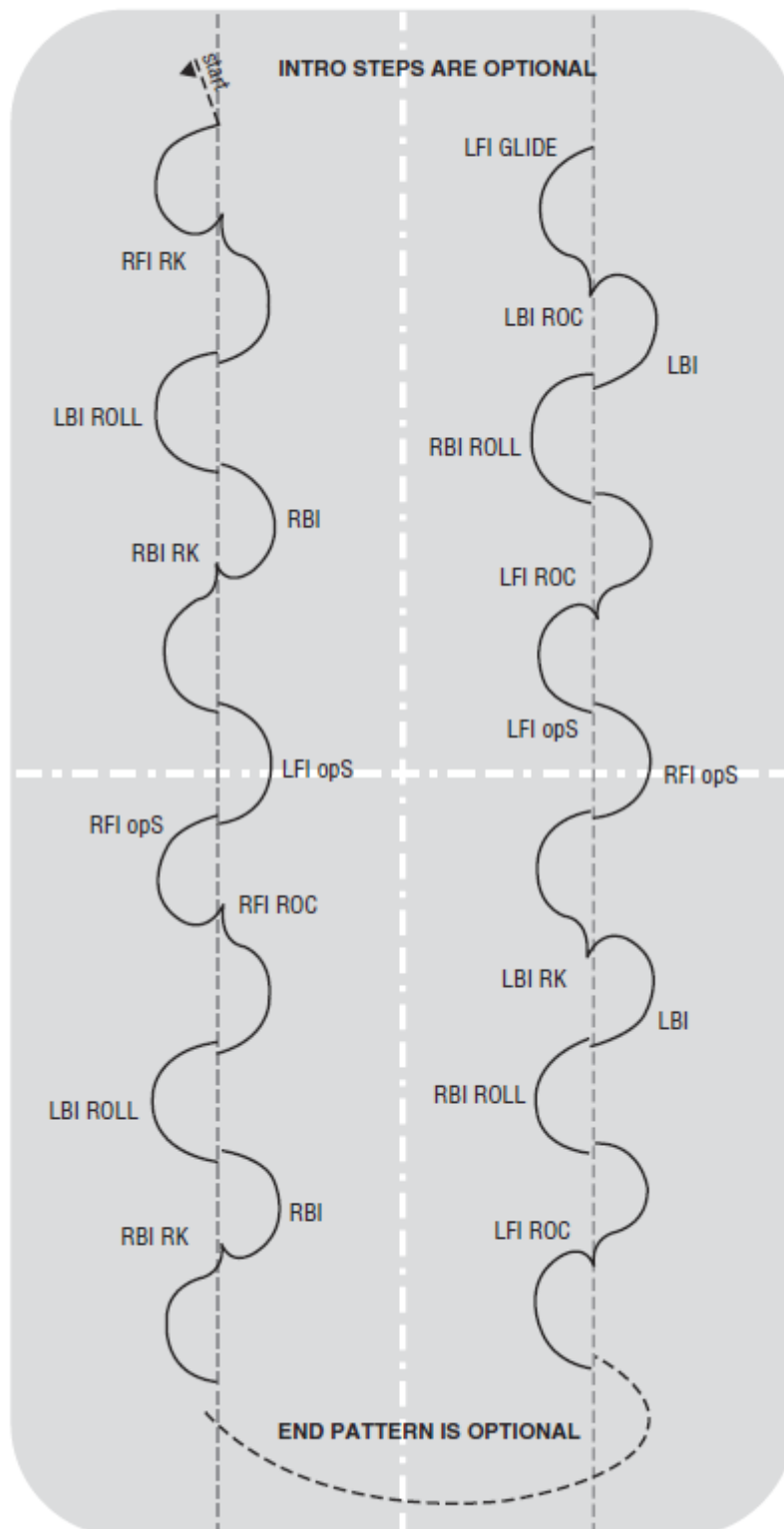

INTER GOLD (TEST 6) STROKING SKILLS TEST

DESCRIPTION

3. Power pulls

The skater will perform a sequence of three power pulls followed by two quick twisting rockers. This sequence is then repeated consecutively down the entire diagonal of the rink. It is then performed on the opposite diagonal of the rink on the other foot. There should be a total of three to four sequences per foot. The introductory and end steps are optional. This move may start on either foot.

Focus: Power and quickness

COMMON ERRORS, AREAS OF DIFFICULTY & TEST EXPECTATIONS

3. Power Pulls

FOCUS: Power and Quickness

| | |
|----|---|
| CE | <ul style="list-style-type: none">-Shallow edges-Slow turns-Noisy-Poor posture-Inability to maintain or increase power-Loss of diagonal axis-Poor upper body control-Sloppy free leg-Power camouflaged by too many introductory steps |
| AD | <ul style="list-style-type: none">-Usually both sets of rockers on the left leg-Creating and maintaining power-Quick turns |
| TE | <ul style="list-style-type: none">-Ability to maintain or increase power upon completion-Fairly quick turns-Quiet except for the 'ripping' sound during the power pulls-Equal power on both legs-Should demonstrate good-excellent control throughout |

Power Pulls

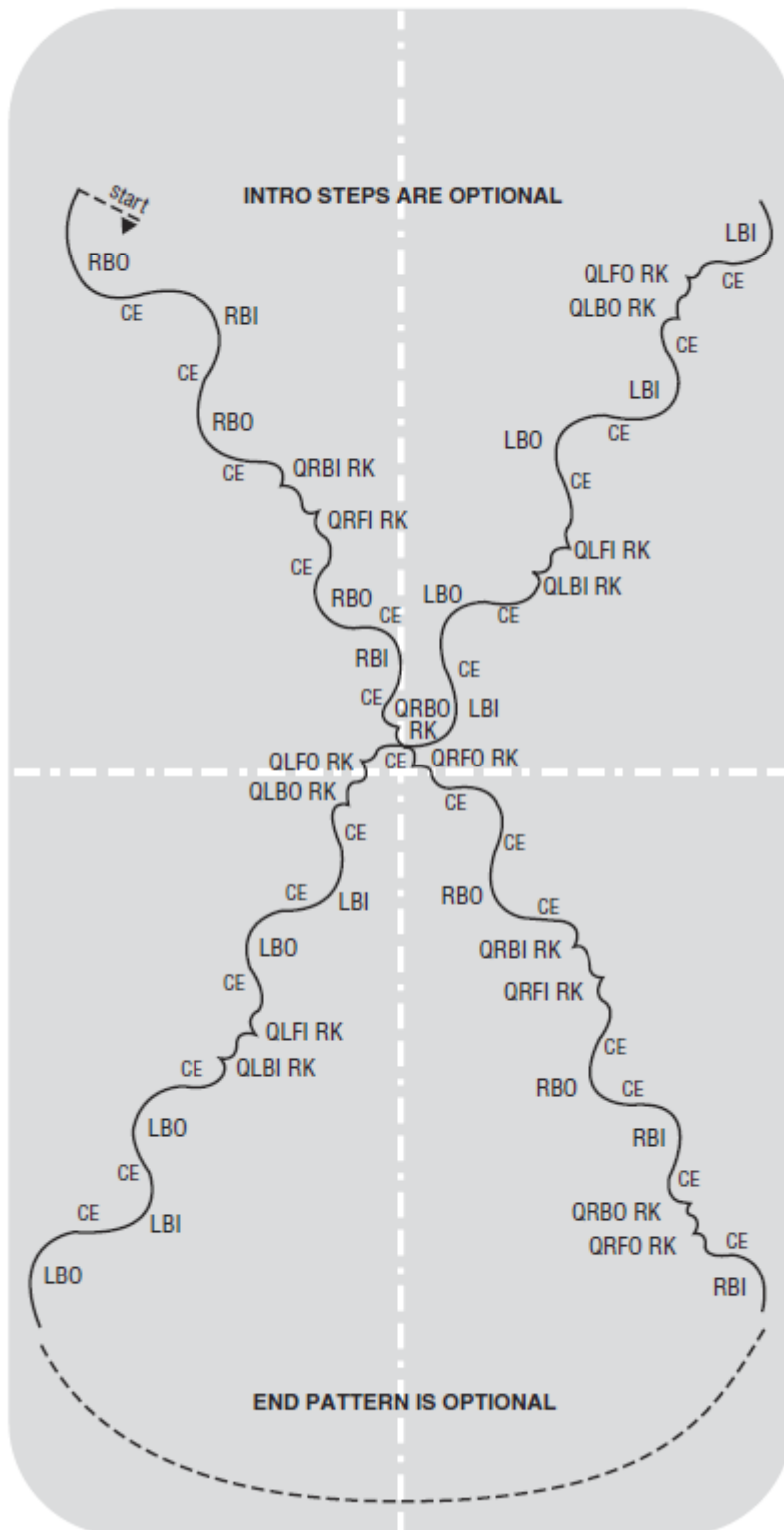

INTER GOLD (TEST 6) STROKING SKILLS TEST

DESCRIPTION

4. Choctaw sequence

The skater will perform a choctaw sequence that covers the entire diagonal length of the rink and which is then repeated on the second diagonal. This sequence is performed with two consecutive choctaws that are then performed in the opposite direction. Introductory steps are optional. This move may start in either direction.

Focus: Edge quality and power

COMMON ERRORS, AREAS OF DIFFICULTY & TEST EXPECTATIONS

4. Choctaw Sequence

FOCUS: Edge quality and power

| | |
|----|--|
| CE | <ul style="list-style-type: none">-Inability to maintain rhythm-Lots of scraping and skidding during the choctaws-Loss of flow-Poor posture |
| AD | <ul style="list-style-type: none">-Entire move-Obtaining an even rhythm-Maintaining flow throughout |
| TE | <ul style="list-style-type: none">-Skated with appropriate power for level-An even rhythm throughout-Good to excellent control of arm carriage-Body alignment should be effortless looking-Generally one set of choctaws will be performed at a higher quality than the other side |

Choctaw Sequence

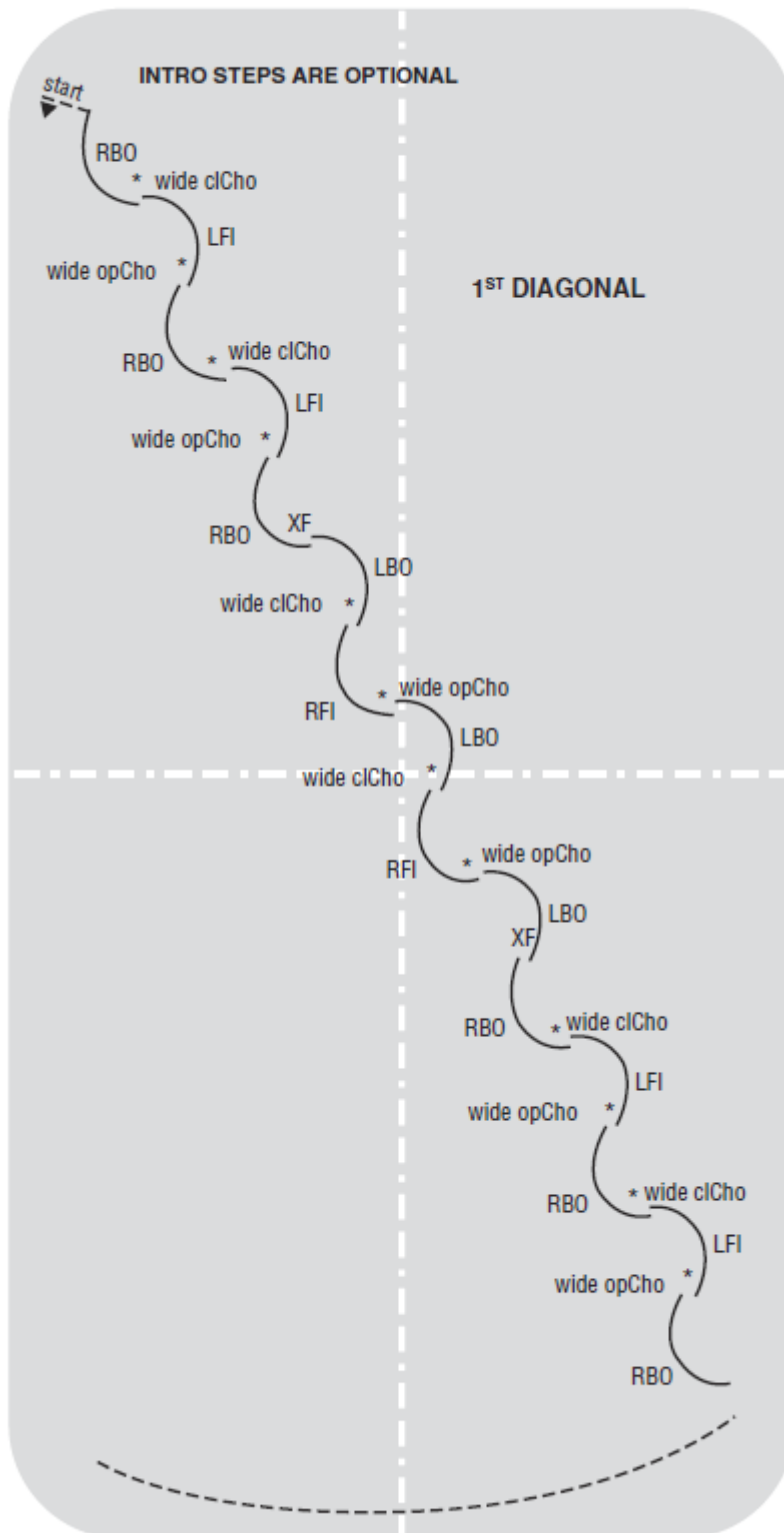

INTER GOLD (TEST 6) STROKING SKILLS TEST

DESCRIPTION

5. Backward loop pattern

Backward outside loops: The skater begins from a standing start with a LFO3 into three BI rolls. The last BI roll is followed by a RBIO change of edge into a RBO loop. The skater then performs a change of edge to push LBI into three more BI rolls followed by a LBIO change of edge into a LBO loop. This sequence should be repeated twice down the length of the rink. Backward inside loops: For this side of the move the skater begins from a standing start with a RFI3 into three backward outside cross strokes. The third cross stroke is immediately connected to a LBOI change of edge into a LBI loop. The skater then performs a change of edge to push into three more BO cross strokes, beginning with RBO. The third cross stroke is immediately connected to a RBOI change of edge into a RBI loop. This sequence should be repeated twice down the length of the arena. Introductory steps are optional. This move may start in either direction.

Focus: Edge quality and continuous flow

COMMON ERRORS, AREAS OF DIFFICULTY & TEST EXPECTATIONS

5. Backward Loop Pattern

FOCUS: Edge quality and continuous flow

| | |
|----|---|
| CE | <ul style="list-style-type: none">-Creates a rounded rather than elongated loop-Lack of control after loop-Lack of upper body control-Two footing on loops-Inability to maintain a consistent flow throughout the entire move |
| AD | <ul style="list-style-type: none">-Control after the loop-Returning to a common axis |
| TE | <ul style="list-style-type: none">-Correct loop action-No touching down with free foot-Good posture and body alignment-Beginning edge should be initiated as close to perpendicular to the axis as possible |

5. Backward Loop Pattern

FOCUS: Edge quality and continuous flow

Backward Loop Pattern

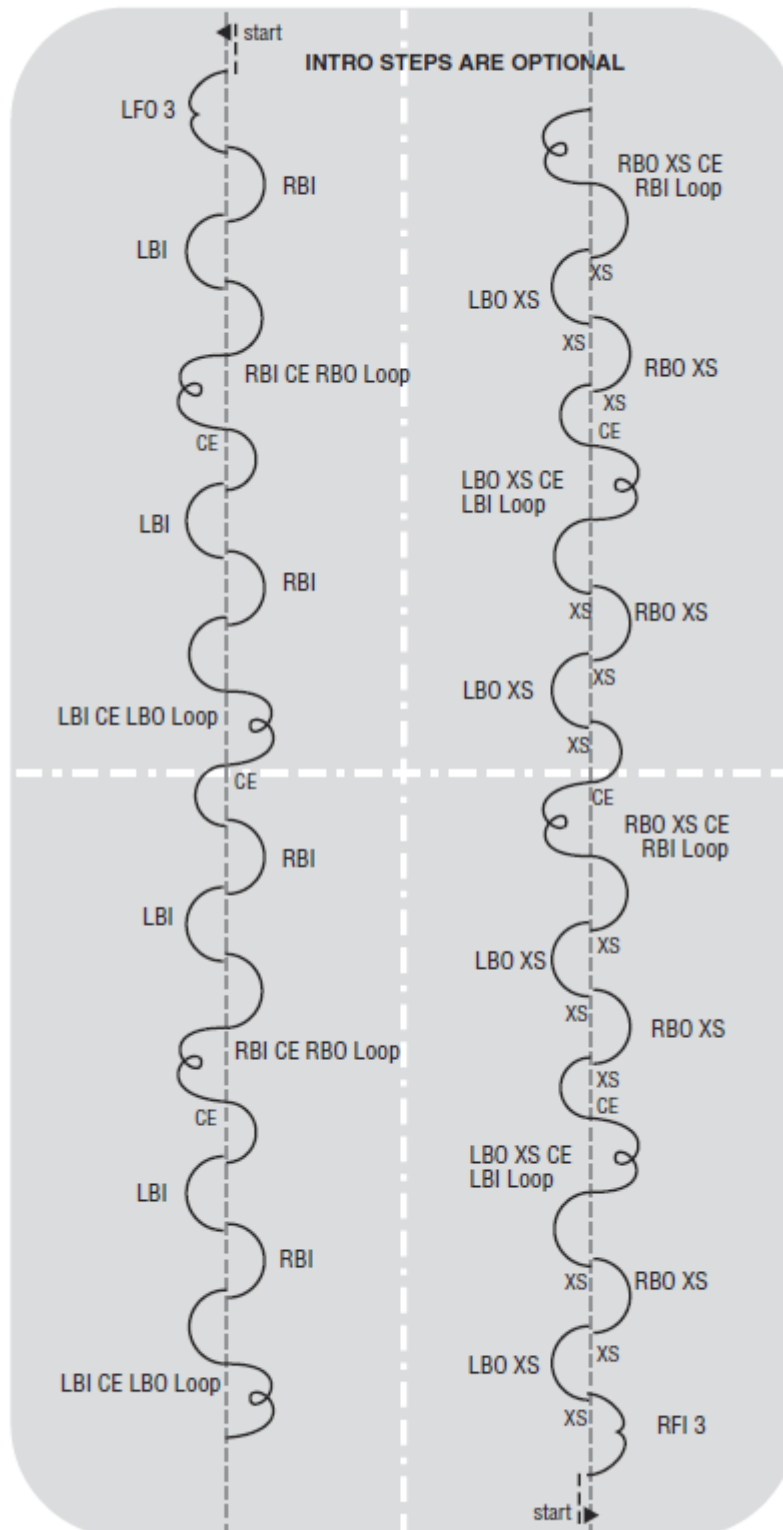

INTER GOLD (TEST 6) STROKING SKILLS TEST

DESCRIPTION

6. Straight line step sequence

The skater begins from a standing start with two open strokes R and L. The skater will perform a RFO rocker and cross forward to LBI rocker, which enters immediately into a LFI counter. Next is a RBO double twizzle, stepping forward into a LFO Chassé to LFO swing counter. The counter is immediately followed by a cross in front to RBI, followed by three clockwise toe steps and another cross in front RBI. The skater then steps forward onto LFI and changes lobe with a 1-1/2 revolution RFI twizzle followed immediately by an edge pull to change edge into a RBI double-three. Finally, the skater pushes into a LBI rocker followed by a LFI rocker, and then a RBI loop. Sequence is to be repeated starting on the other foot. This move may start in either direction and may be done down the midline or diagonally.

Focus: Edge quality and continuous flow

COMMON ERRORS, AREAS OF DIFFICULTY & TEST EXPECTATIONS

6. Straight Line step Sequence **FOCUS: Edge quality and continuous flow**

| | |
|----|--|
| CE | <ul style="list-style-type: none">-Poor quality of turns-Lack of rhythm or timing-Poor posture-Lack of use of arms |
| AD | <ul style="list-style-type: none">-Maintaining flow throughout-Multidirectional-Equal quality of turns/steps on both feet-Chassé into swing counter-Rocker, rocker before loop |
| TE | <ul style="list-style-type: none">-Apply GOE reduction guidelines and positive bullet charts for IJS-Good flow and speed-Utilises full length of ice surface |

6. Straight Line step Sequence

FOCUS: Edge quality and continuous flow

Straight Line Step Sequence

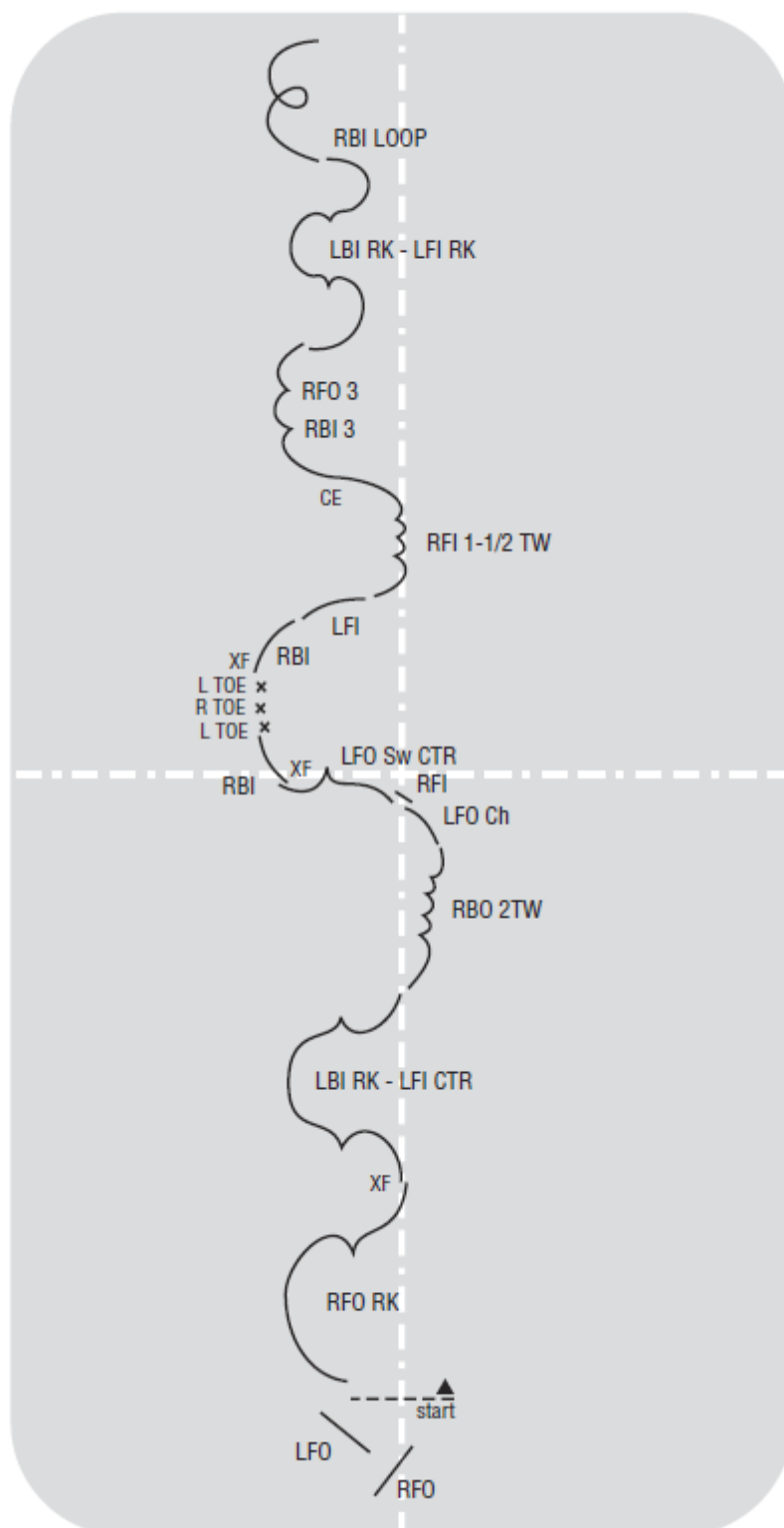

GOLD (TEST 7) STROKING SKILLS TEST

1. Sustained Edge Step
2. Spiral Sequence
3. Backward Outside Power Double Three-Turns to Power Double Inside Rockers
4. Backward Inside Power Double Three-Turns to Power Double Outside Rockers
5. Serpentine Step Sequence

GOLD (TEST 7) STROKING SKILLS TEST

DESCRIPTION

1. Sustained edge step

The skater will powerfully perform a BI three-turn to a sustained swing change of edge followed by a FI rocker, stepping to a BI double three-turn. Backward crossover steps follow this sequence. This pattern is then repeated to cover the entire surface of the rink. The skater will then repeat this step in the opposite direction. Introductory steps are optional. This move may start in either direction.

Focus: Edge Quality and power

COMMON ERRORS, AREAS OF DIFFICULTY & TEST EXPECTATIONS

1. Sustained Edge Step

FOCUS: Edge quality and Power

| | |
|----|---|
| CE | <ul style="list-style-type: none">- Inability to maintain a consistent flow throughout the entire move-Incomplete ice coverage-Poor upper body line-Three-turn instead of rocker-Poor extension |
| AD | <ul style="list-style-type: none">-Creating power throughout-Ice coverage |
| TE | <ul style="list-style-type: none">-Skater should demonstrate control with all body positions-Excellent body line and extension-Equal power throughout-Should be a rocker (not a three-turn)-LOOK – excellent form and extension; SEE – you are totally comfortable watching the complete execution of the move (skater should demonstrate good use of knees); HEAR – ‘ripping’ sounds and power strokes |

1. Sustained Edge Step

FOCUS: Edge quality and Power

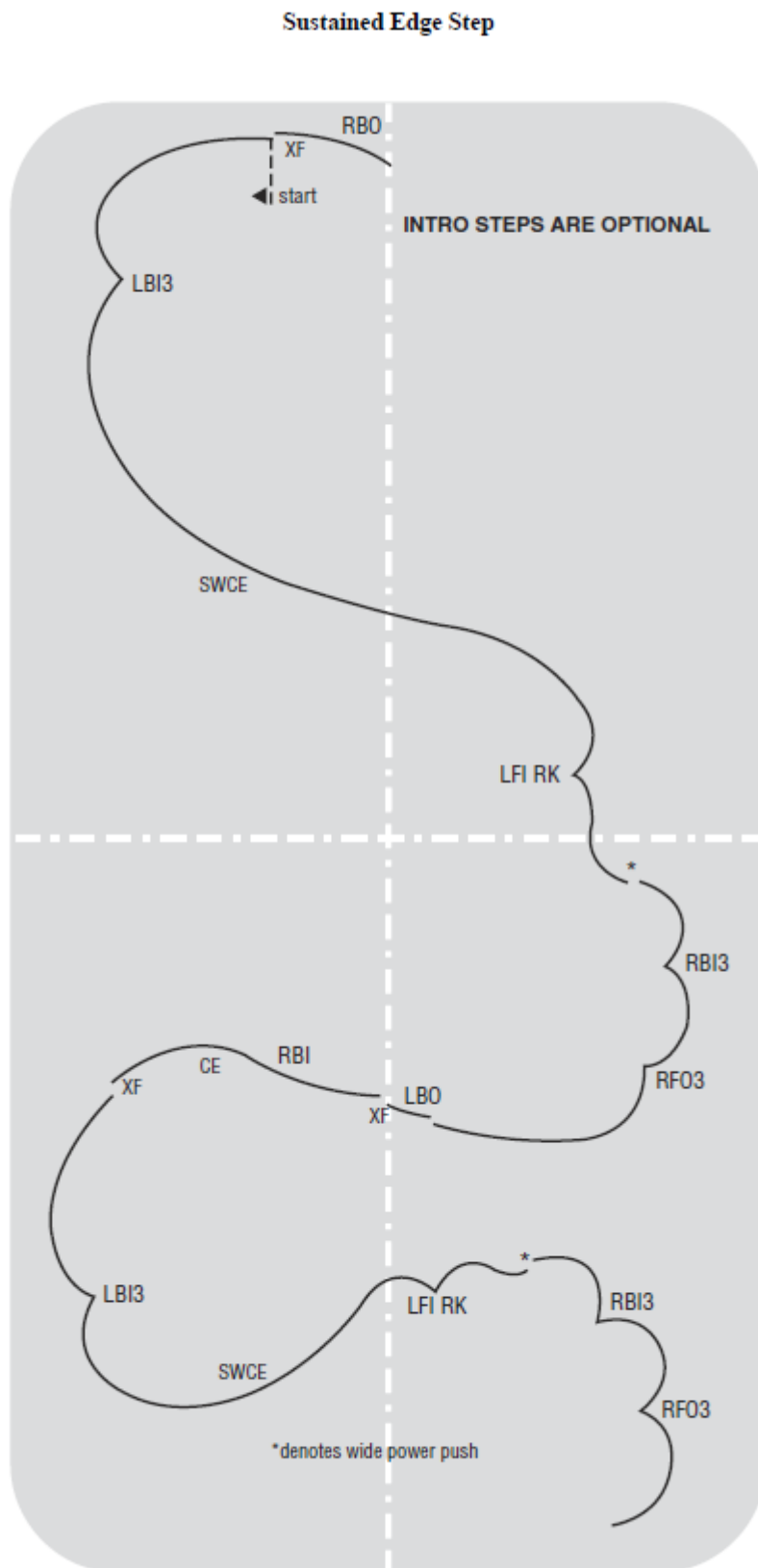

GOLD (TEST 7) STROKING SKILLS TEST

DESCRIPTION

2. Spiral sequence

The skater begins with a series of spirals, transitioning from a RBO spiral to a RFI spiral through the use of a RBO3 that is parallel to the long barrier of the rink. The free leg is then lowered into a RFI open mohawk and steps wide with a two-foot power push transition into two backward R over L crossovers. The skater steps onto a LFI and then immediately onto a RFI-RBO spiral sequence, again transitioning between spirals with a RFI3. The skater then does a cross stroke behind LBO swing roll followed by a RFO triple three-turn. Then step LFI into a RFI3, followed by a step forward into a LFO crossover and finally a LFO spiral. The pattern is repeated in the opposite direction, and transition steps are optional. (NOTE: All spirals should be sustained with an extended free leg to demonstrate the skater's form and flexibility). This move may start in either direction. Introductory steps are optional.

Focus: Extension and edge quality

COMMON ERRORS, AREAS OF DIFFICULTY & TEST EXPECTATIONS

2. Spiral Sequence

FOCUS: Extension and Edge quality

| | |
|----|---|
| CE | <ul style="list-style-type: none">- Inability to maintain a consistent flow throughout the entire move-Poor ice coverage-Poor pattern-Open mohawks are weak-Poor extension-Spirals not held or sustained on an excellent edge |
| AD | <ul style="list-style-type: none">-Second half of pattern-Ability to maintain a consistent flow throughout the entire move-Maintaining speed throughout |
| TE | <ul style="list-style-type: none">-Excellent symmetric ability of extension-Expect pleasing presentation and excellent edges during spirals-Excellent ice coverage-Should see basic spiral position (no variations such as holding the knee or blade)-LOOK – excellent form and extension; SEE – you are totally comfortable watching the complete execution of the move (skater should demonstrate good use of knees); HEAR – ‘ripping’ sounds and power strokes |

2. Spiral Sequence

FOCUS: Extension and Edge quality

Spiral Sequence

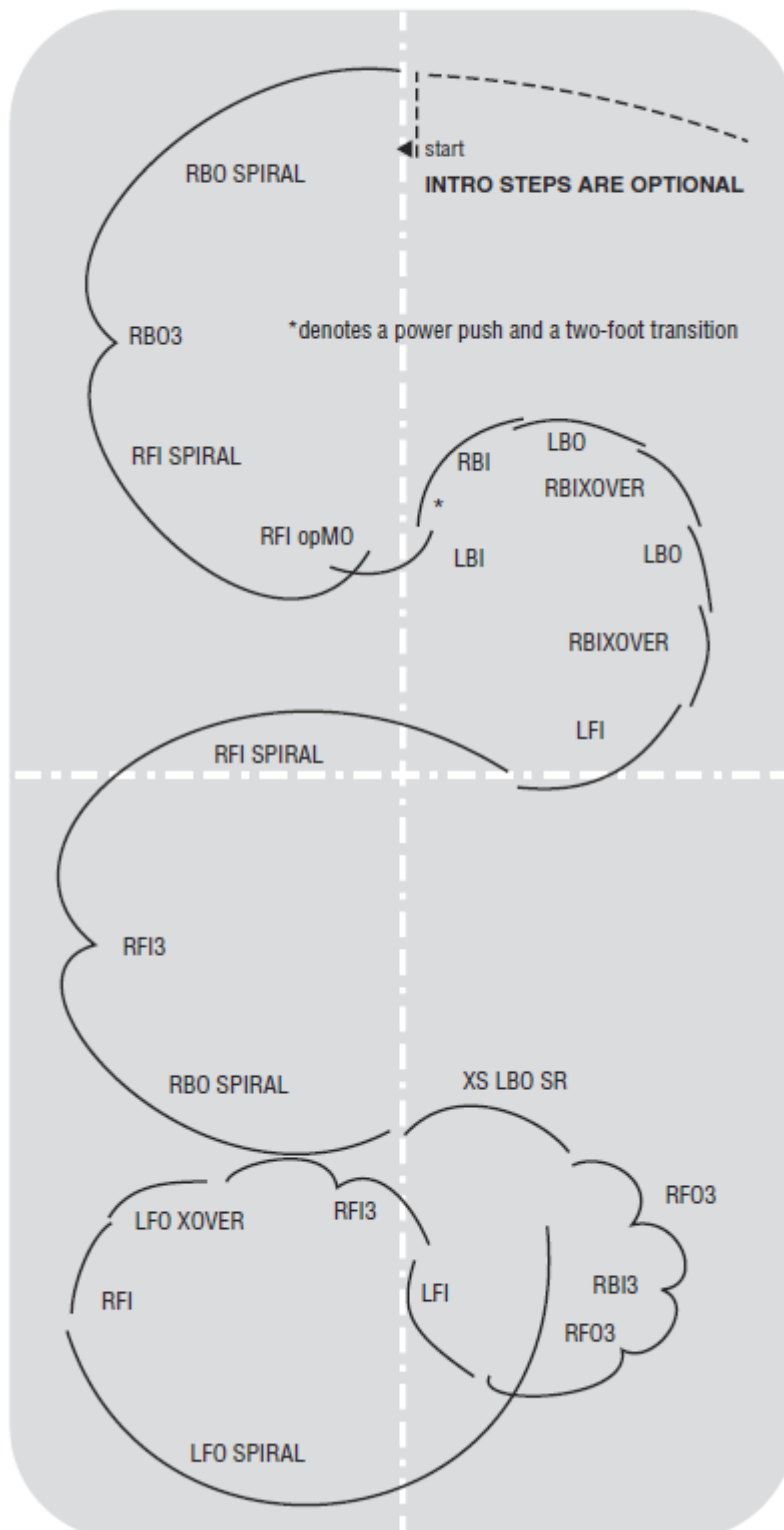

GOLD (TEST 7) STROKING SKILLS TEST

DESCRIPTION

3. Backward outside power double three-turns to power double inside rockers

The skater will perform BO power double three-turns then complete a power pull to BI double rockers. These rockers are immediately followed by another power pull. This sequence is repeated consecutively down the entire diagonal of the rink. The skater will then perform the same step using the opposite foot down the opposite diagonal of the rink. Introductory steps are optional. This move may start on either foot.

Focus: Power and quickness

COMMON ERRORS, AREAS OF DIFFICULTY & TEST EXPECTATIONS

3. Backward outside power double three-turns to power double inside rockers

FOCUS: Power and Quickness

| | |
|----|--|
| CE | <ul style="list-style-type: none">-Using too many introductory steps to camouflage lack of power-Loss of flow during the move-Shallow changes of edge-Poor control of upper body-Loss of diagonal axis-Inability to maintain or increase power |
| AD | <ul style="list-style-type: none">-Left set of double threes and rockers-Entire move-Double three-turns and rockers equidistant from the axis-Ability to create power throughout the move |
| TE | <ul style="list-style-type: none">-Noticeable quality of power throughout-Good to excellent control of upper body through the double three-turns to the double rockers-Rocker turns should be quicker than the threes in timing-Maintaining a consistent flow and power throughout-LOOK – excellent form and extension; SEE – you are totally comfortable watching the complete execution of the move (skater should demonstrate good use of knees); HEAR – ‘ripping’ sounds and power strokes |

3. Backward outside power double three-turns to power double inside rockers
FOCUS: Power and Quickness

BO Power Double Three-Turns to Power Double Inside Rockers

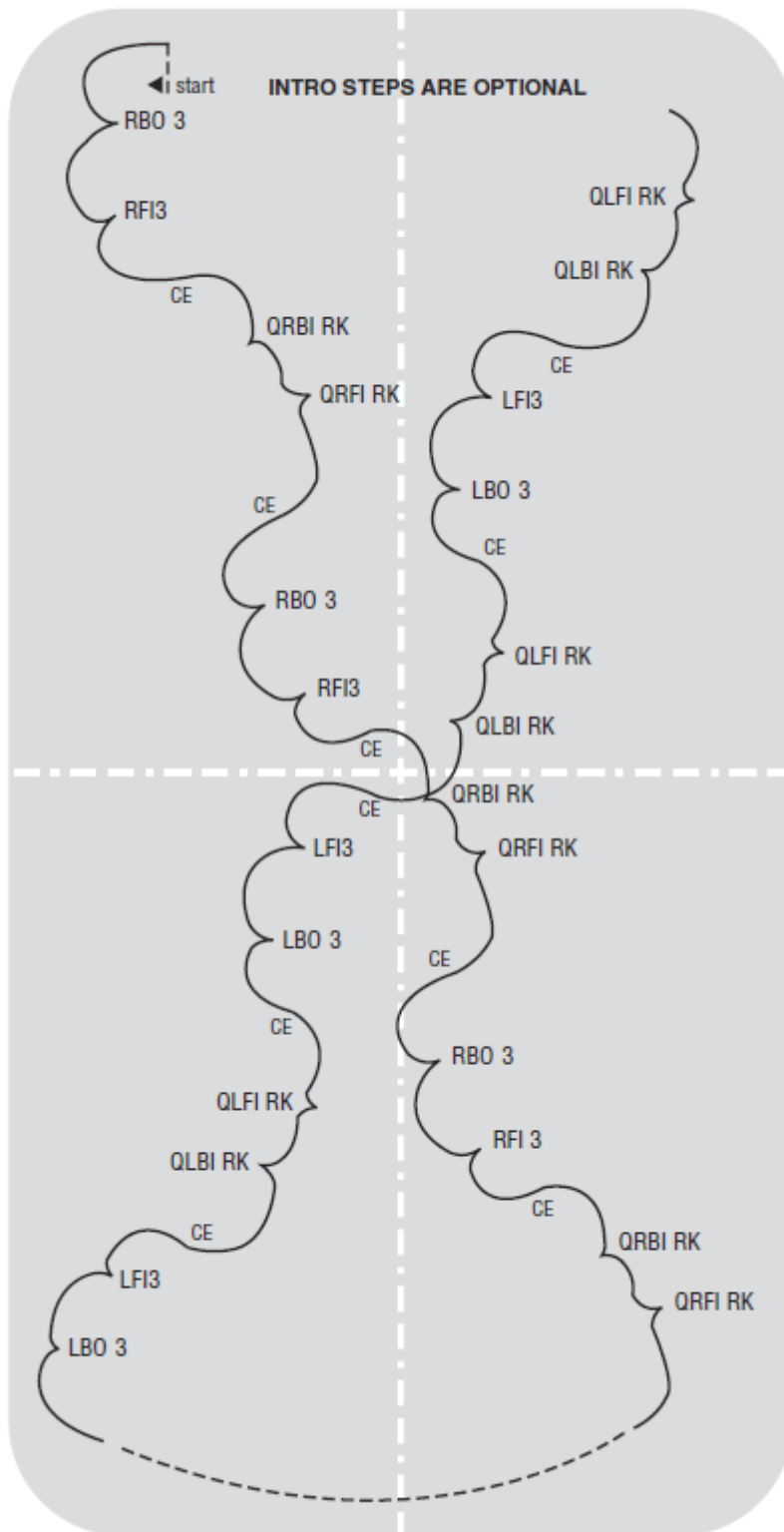

GOLD (TEST 7) STROKING SKILLS TEST

DESCRIPTION

4. Backward inside power double three-turns to power double outside rockers

The skater will perform BI power double three-turns, then complete a power pull to BO double rockers. These rockers are immediately followed by another power pull and the sequence is then repeated consecutively down the entire diagonal of the rink. The skater will then perform the same step using the opposite foot down the opposite diagonal of the rink. Introductory steps are optional. This move may start on either foot.

Focus: Power and quickness

COMMON ERRORS, AREAS OF DIFFICULTY & TEST EXPECTATIONS

4. Backward inside power double three-turns to power double outside rockers

FOCUS: Power and Quickness

| | |
|----|--|
| CE | <ul style="list-style-type: none">-Using too many introductory steps to camouflage lack of power-Loss of flow during the move-Shallow changes of edge-Poor control of upper body-Loss of diagonal axis-Inability to maintain or increase power |
| AD | <ul style="list-style-type: none">-Entire move-Maintaining flow-Double three-turns and rockers equidistant from the axis-Ability to create power throughout the move |
| TE | <ul style="list-style-type: none">-Noticeable quality of power throughout-Good to excellent control of upper body through the double three-turns to the double rockers-Rocker turns should be quicker than the threes in timing-Maintaining a consistent flow and power throughout-LOOK – excellent form and extension; SEE – you are totally comfortable watching the complete execution of the move (skater should demonstrate good use of knees); HEAR – ‘ripping’ sounds and power strokes |

4. Backward inside power double three-turns to power double outside rockers
FOCUS: Power and Quickness

BI Power Double Three-Turns to Power Double Outside Rockers

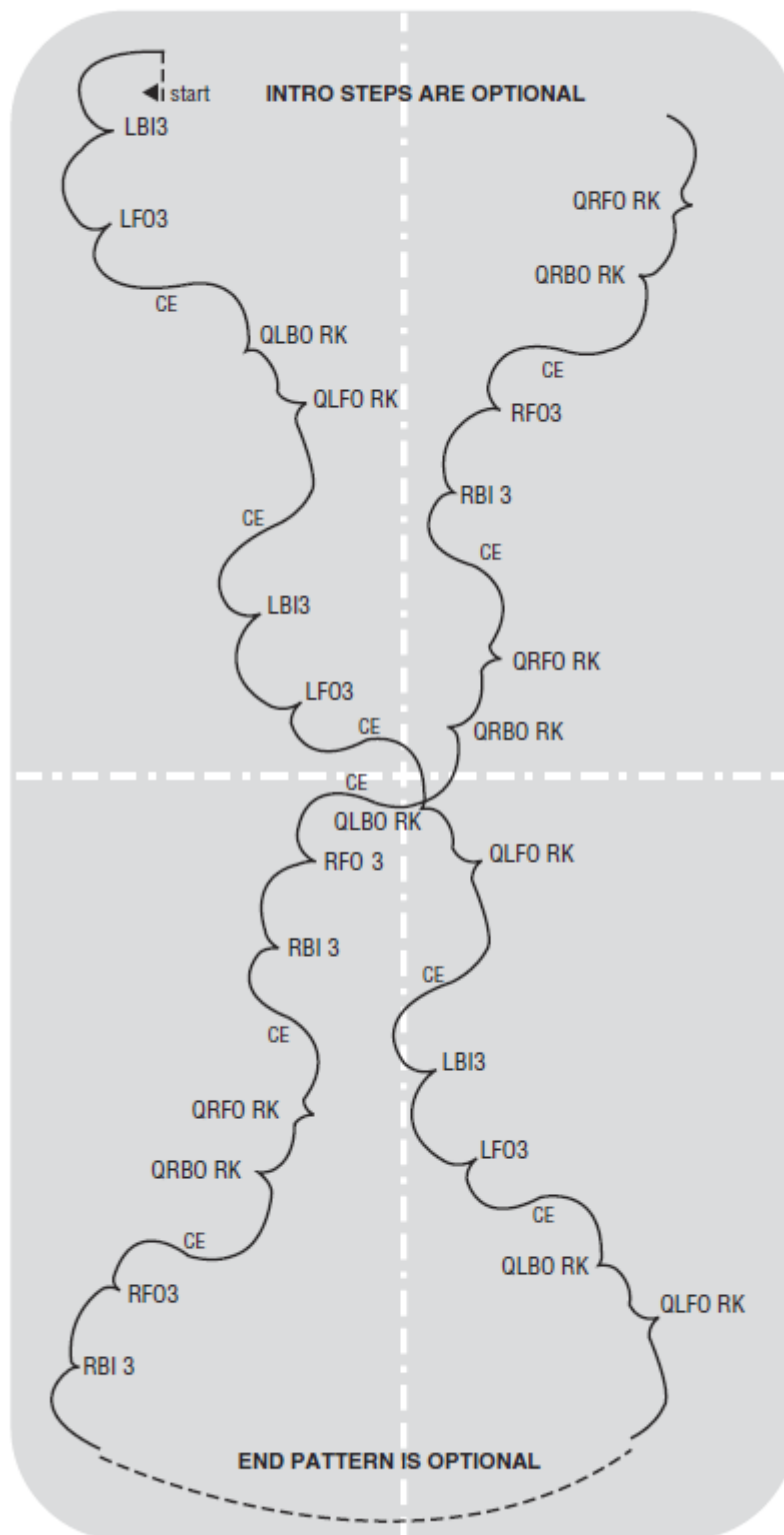

GOLD (TEST 7) STROKING SKILLS TEST

DESCRIPTION

5. Serpentine step sequence

The skater begins with a RFO3 followed by a LBO double three-turn. The free leg then crosses in front for a RBI. This edge is followed by three clockwise toe steps and another cross in front RBI. Next the skater will step forward onto a LFO edge and perform a 2-1/2 revolution RFI twizzle, ending with a LBO cross stroke behind three-turn. This turn will initiate a series of quick mohawk turns followed by a quick LBI. Next is a RBI counter into a RFI rocker. The skater steps LBI then a step- wide into RBI rocker, RFI mohawk, LBI bracket sequence. The skater should then simultaneously cross behind and reverse arm position to do RFI bracket into RBO counter, followed by a LFO cross front, RFI cross behind. The final part of the sequence is an open RFI/LBO double choctaw followed immediately by a RFI counter, then push to LBI double twizzle, and finishes with a RBI loop. Optional steps take the skater to the repeat of the sequence in the opposite direction. The skater has the option of starting in either direction. Introductory steps are optional.

Focus: Edge quality and continuous flow

COMMON ERRORS, AREAS OF DIFFICULTY & TEST EXPECTATIONS

5. Serpentine step Sequence

FOCUS: Edge quality and continuous flow

| | |
|----|---|
| CE | <ul style="list-style-type: none">-Poor quality of turns-Lack of rhythm or timing-Poor posture-Lack of use of arms |
| AD | <ul style="list-style-type: none">-Maintaining flow throughout-Multidirectional-Equal quality of turns/steps on both feet |
| TE | <ul style="list-style-type: none">-Apply GOE reduction guidelines and positive bullet charts for IJS-Good flow and speed-Fully utilises ice surface |

5. Serpentine step Sequence

FOCUS: Edge quality and continuous flow

Serpentine Step Sequence

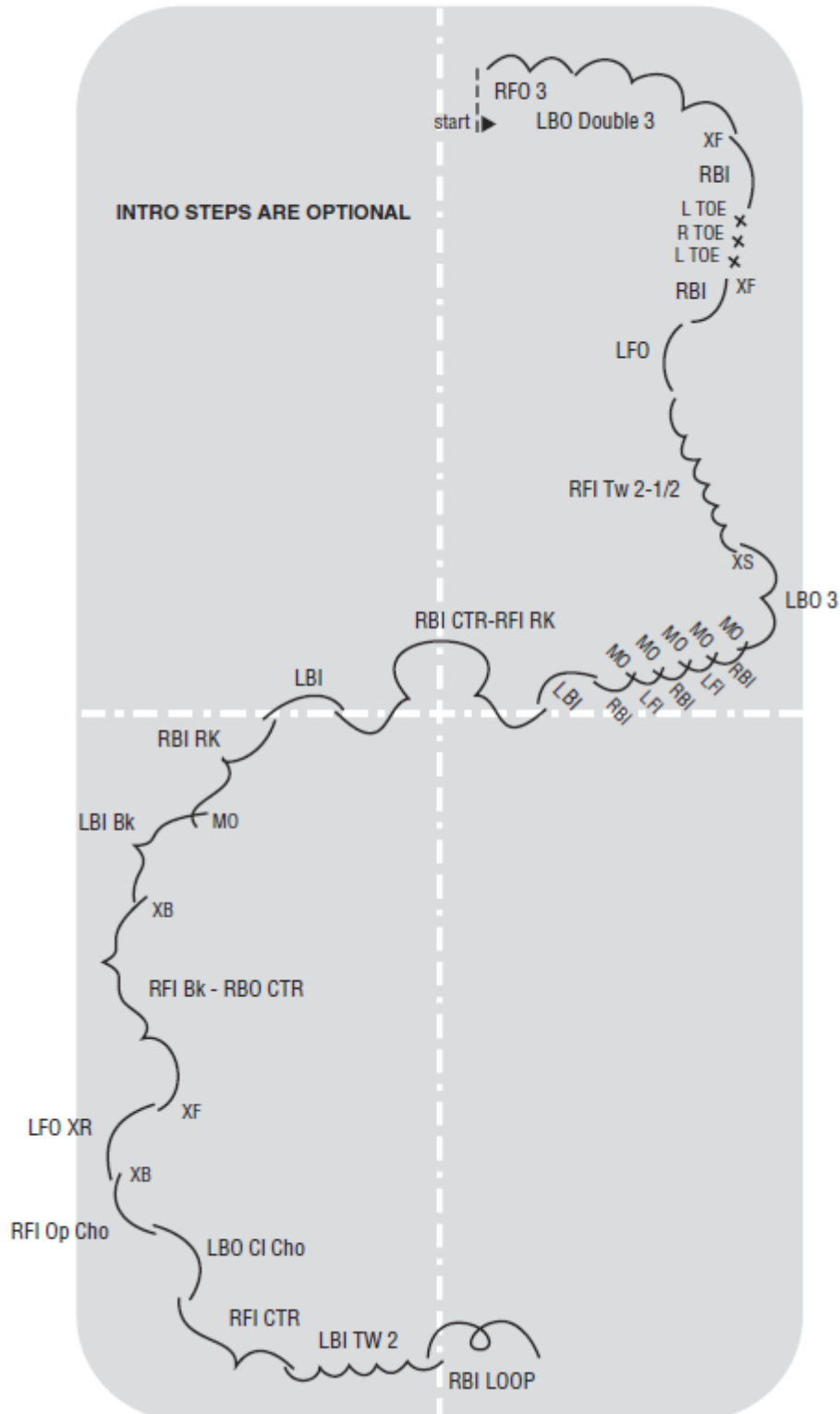

Serpentine Step Sequence — Repeat

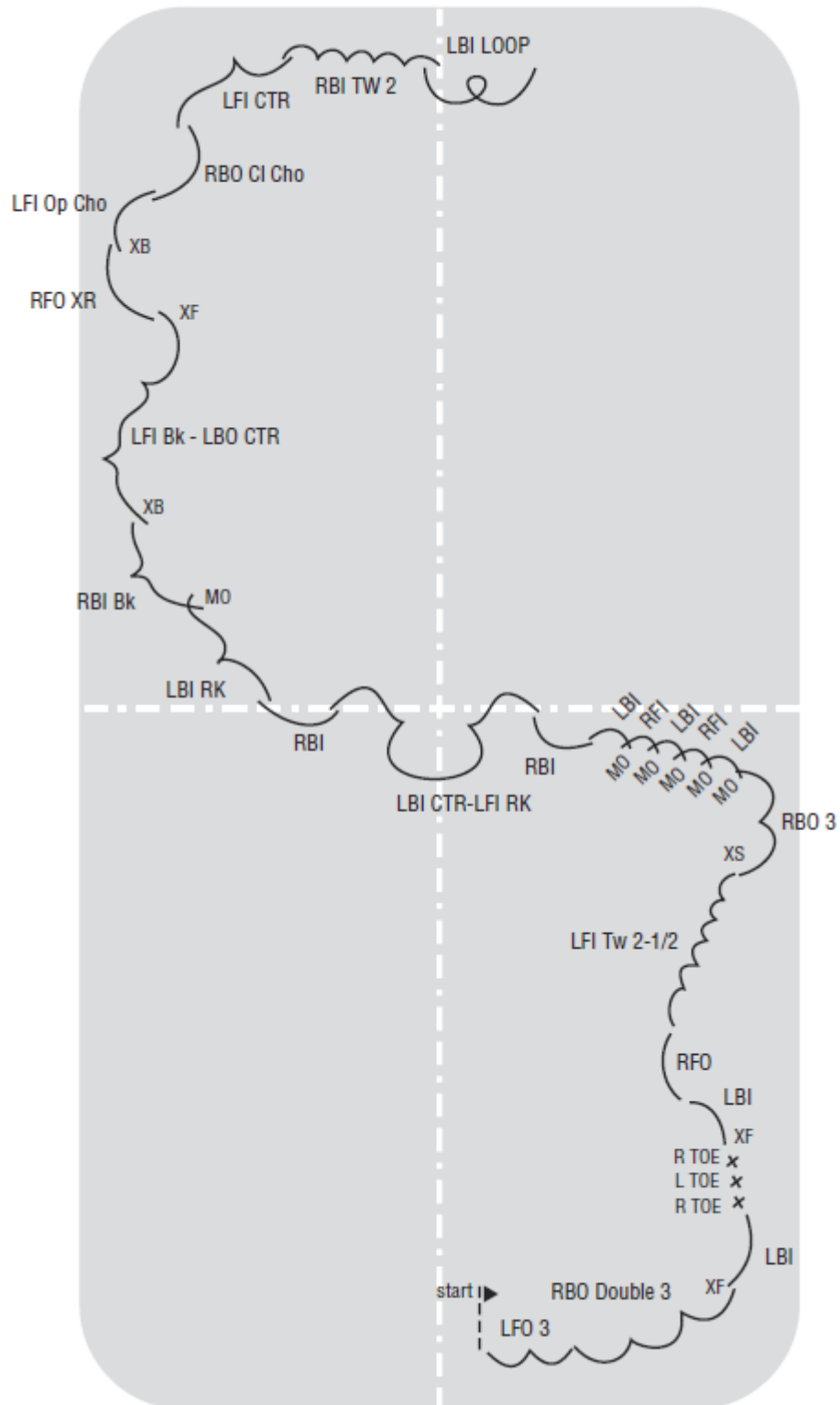

GOLD STAR (TEST 8) STROKING SKILLS TEST

1. Accelerating Mohawks, Choctaws and Gallops
2. Creative Exercises
3. Expanding Exercises

GOLD STAR (TEST 8) STROKING SKILLS TEST

DESCRIPTION

The skater performs a figure eight pattern covering the entire ice surface. Open choctaws are performed across the diagonal with closed outside mohawks around the ends. This move must be skated in the direction shown in the diagram. Two “laps” of the rink will be skated. This exercise is performed with a 4/4 time signature at 120bpm.

COMMON ERRORS, AREAS OF DIFFICULTY & TEST EXPECTATIONS

1. Accelerating Mohawks, Choctaws and Gallops

FOCUS: Agility (quickness) and Power

| | |
|----|--|
| CE | <ul style="list-style-type: none">-Slowness of timing of steps in comparison to beat of music-Sacrifice of quality of edges in order to show agility-Incorrect mohawk performed |
| AD | <ul style="list-style-type: none">-Correct timing of steps with best of music-Maintaining edge quality while showing agility and power |
| TE | <ul style="list-style-type: none">-Steps performed in time with beat of music-Well-controlled arms and feet-Power maintained or increased during exercise-Difference between open and closed mohawks demonstrated-Both directions should be equal in quality |

1. Accelerating Mohawks, Choctaws and Gallops

FOCUS: Agility (quickness) and Power

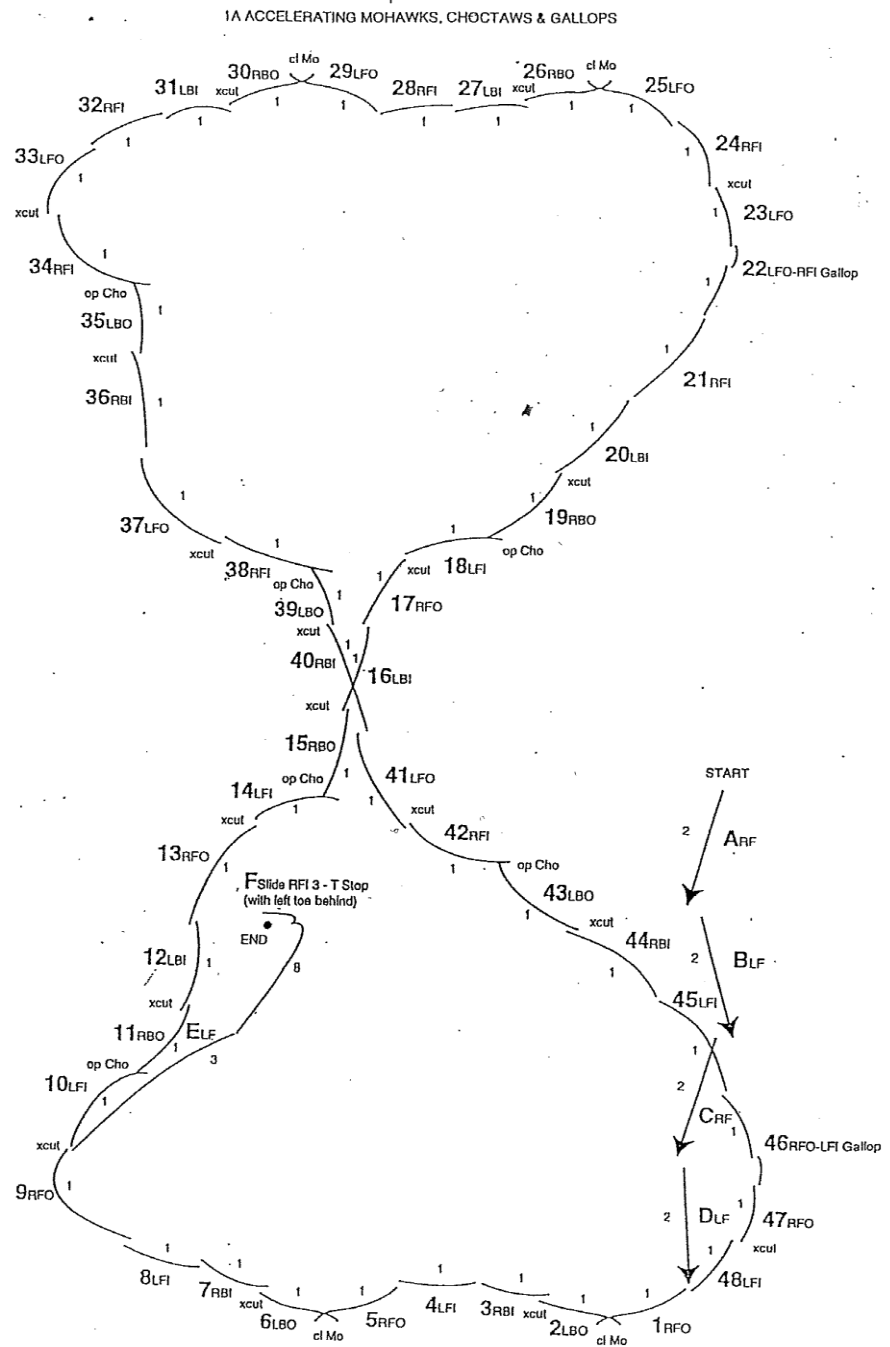

Two sequences to be skated.

FOCUS: AGILITY
POWER

Time Signature = 4/4
Tempo = 120 bpm

1. Accelerating Mohawks, Choctaws and Gallops

FOCUS: Agility (quickness) and Power

| Step No. | Step | No. of Beats | Step No. | Step | No. of Beats |
|----------|----------------|--------------|----------|--|--------------|
| A | RF | 2 | 25 | LFO | 1 |
| B | LF | 2 | | cl MO | |
| C | RF | 2 | 26 | RBO | 1 |
| D | LF | 2 | | xover | |
| 1 | RFO | 1 | 27 | LBI | 1 |
| | cl Mo | | | | |
| 2 | LBO | 1 | 28 | RFI | 1 |
| | xover | | 29 | LFO | 1 |
| 3 | RBI | 1 | | cl MO | |
| 4 | LFI | 1 | 30 | RBO | 1 |
| 5 | RFO | 1 | | xover | |
| | cl Mo | | 31 | LBI | 1 |
| 6 | LBO | 1 | 32 | RFI | 1 |
| | xover | | 33 | LFO | 1 |
| 7 | RBI | 1 | | xover | |
| 8 | LFI | 1 | 34 | RFI | 1 |
| 9 | RFO | 1 | | op Cho | |
| | xover | | 35 | LBO | 1 |
| 10 | LFI | 1 | | xover | |
| | op Cho | | 36 | RBI | 1 |
| 11 | RBO | 1 | 37 | LFO | 1 |
| | xover | | | xover | |
| 12 | LBI | 1 | 38 | RFI | 1 |
| 13 | RFO | 1 | | op Cho | |
| | xover | | 39 | LBO | 1 |
| 14 | LFI | 1 | | xover | |
| | op Cho | | 40 | RBI | 1 |
| 15 | RBO | 1 | 41 | LFO | 1 |
| | xover | | | xover | |
| 16 | LBI | 1 | 42 | RFI | 1 |
| 17 | RFO | 1 | | op Cho | |
| | xover | | 43 | LBO | 1 |
| 18 | LFI | 1 | | xover | |
| | op Cho | | 44 | RBI | 1 |
| 19 | RBO | 1 | 45 | LFI | 1 |
| | xover | | 46 | RFO-LFI Gallop | 1 |
| 20 | LBI | 1 | 47 | RFO | 1 |
| 21 | RFI | 1 | | xover | |
| 22 | LFO-RFI Gallop | 1 | 48 | LFI | 1 |
| 23 | LFO | 1 | | Repeat steps 1-48 + Steps 1-9 | |
| | xover | | E | LF | 3 |
| 24 | RFI | 1 | F | Slide RFI 3- T Stop (with left toe behind) | 8 |

GOLD STAR (TEST 8) STROKING SKILLS TEST

2. Creative Exercises

FOCUS: Variety and Power

DESCRIPTION

The skater must perform an exercise which contains three step sequences – one straightline, one circle and one serpentine in shape. Field movements must be included. The creative exercise is performed to music of the skater's choice. The minimum tempo is 112 beats per minute and any time signature is acceptable. Vocal music may be used. The music may not exceed two minutes in length.

This exercise focuses on variety and power. Variety can be created by:

- Length of edge
- Circle size
- Circle direction
- Speed
- Type of turns
- Direction of turns
- Hops (maximum of ½ revolution)
- Field movements
- Edge and toe steps

COMMON ERRORS, AREAS OF DIFFICULTY & TEST EXPECTATIONS

2. Creative Exercises

FOCUS: Variety and Power

| | |
|----|--|
| CE | -Lack of variety of turns, steps and field movements -Lack of power shown |
| AD | -Maintaining power while performing variety of turns, steps and field movements -Loss of flow during steps, turns, and field movements -Ability to demonstrate turns of equal quality in both directions |
| TE | - Variety of turns, steps and field movements performed during exercise -Turns should be executed with good quality edges -Power maintained even if tempo of music changes -Variety of turns, steps and field moves performed -A variety of steps and turns performed in both directions -Well-controlled upper body and arms throughout exercise |

GOLD STAR (TEST 8) STROKING SKILLS TEST

DESCRIPTION

3. Expanding Exercises (CW, CCW)

FOCUS: Edge quality and Balance

This exercise concludes the expanding process. There is a forward pivot following the backward pivot, and multiple turn combinations following the loop. All the fundamental movements in skating are incorporated into this exercise. All are based on the four basic edges.

The FO pivot continues on the same foot as the BO pivot but in the opposite direction. The toe remains in the ice and the body weight is primarily on the forward outside edge. The pivot is one revolution on a small circle. At the conclusion of the pivot, the skater lifts the toe and executes a forward outside-inside change of edge to begin the rocker-counter step.

The skater remains on two feet for Step 29a during the forward inside rocker. The backward edge changes from inside to outside, as the turn is skated. The skater transfers to one foot for Step 29b and executes a BI loop. Step 29 has 8 counts. The rocker is performed on count 1 and the loop on 2, 3, 4, 5, 6, 7, and 8.

The exercise concludes with travelling three turns and three turn/mohawk combinations in both directions. The travelling turns must flow on large curves with an even pace. There is one count for the entry edge and the turns are on counts 2, 3, 4. There is a wide push before each BO three turn similar to a backward crossover. There are two beats for each entry edge, with the three-turn on count 3 and the mohawk on count 4.

COMMON ERRORS, AREAS OF DIFFICULTY & TEST EXPECTATIONS

3. Expanding Exercises (CW, CCW)

FOCUS: Edge quality and Balance

| | |
|----|--|
| CE | <ul style="list-style-type: none">-Poor carriage and body line-One direction (usually clockwise) weaker in execution-Slowness of timing of steps in comparison to beat of music-Small size of 'Maltese Cross' section/ lack of movement across ice while performing turns after pivot |
| AD | <ul style="list-style-type: none">-Timing of steps-Usually clockwise direction weaker-Maintaining flow throughout the exercise-Edge quality throughout |
| TE | <ul style="list-style-type: none">-Steps performed in time with beat of the music-Well-controlled arms and feet-Both directions should be equal in quality-Edge quality maintained throughout exercise-Excellent form and extension |

3. Expanding Exercises (CW)

FOCUS: Edge quality and Balance

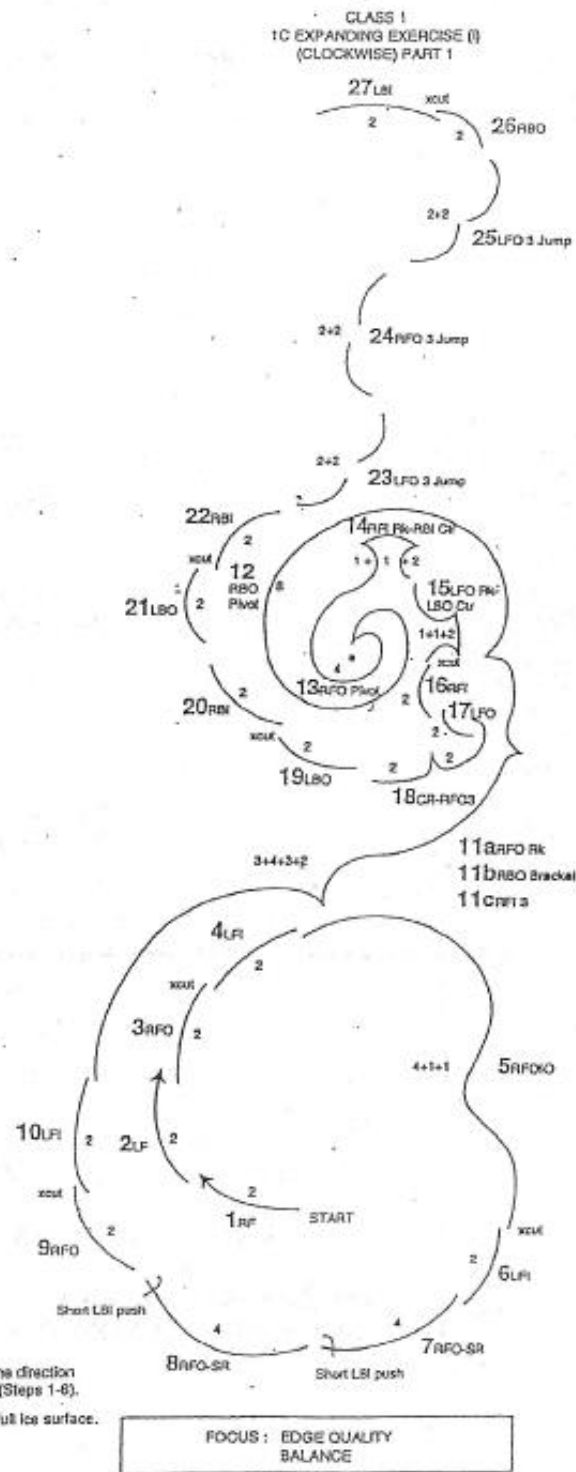

3. Expanding Exercises (CW)

FOCUS: Edge quality and Balance

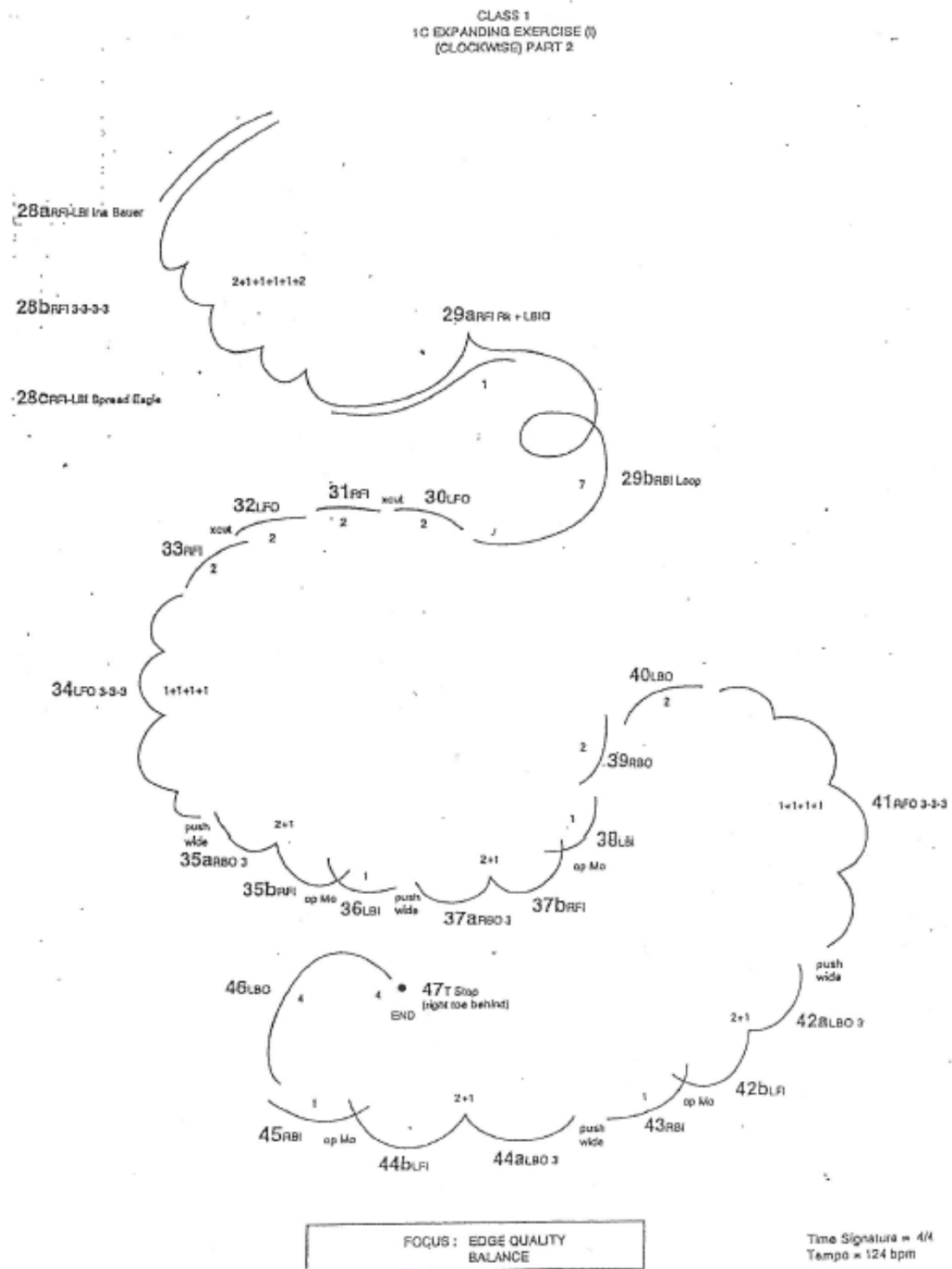

3. Expanding Exercises (CW)

FOCUS: Edge quality and Balance

| Step No. | Step | No. of Beats | Step No. | Step | No. of Beats |
|----------|-----------------------------------|--------------|----------|----------------------------------|--------------|
| 1 | RF | 2 | 27 | LBI | 2 |
| 2 | LF | 2 | 28a | RFI-LBI Ina Bauer | 2+ |
| | | | 28b | RFI 3-3-3-3 | 1+ 1+1+1 |
| | | | 28c | RFI-LBI Spread Eagle | +2 |
| 3 | RFO | 2 | 29a | RFI Rk + LBIO (both feet on ice) | 1+7 |
| | xover | | 29b | RBI Loop | |
| 4 | LFI | 2 | 30 | LFO | 2 |
| 5 | RFOIO | 4+1+1 | | xover | |
| | xover | | 31 | RFI | 2 |
| 6 | LFI | 2 | 32 | LFO | 2 |
| 7 | RFO-SR | 4 | | xover | |
| | Followed by a very short LBI push | | 33 | RFI | 2 |
| 8 | RFO-SR | 4 | 34 | LFO 3-3-3 | 1+1+1+1 |
| | Followed by a very short LBI push | | | push wide | |
| 9 | RFO | 2 | 35a | RBO 3 | 2+1 |
| | xover | | 35b | RFI | |
| 10 | LFI | 2 | | op Mo | |
| 11a | RFO Rk | 3+4+3+2 | 36 | LBI | 1 |
| 11b | RBO Bracket | | | push wide | |
| 11c | RFI 3 | | 37a | RBO 3 | 2+1 |
| 12 | RBO Pivot | 8 | 37b | RFI | |
| 13 | RFO Pivot | 4 | | op MO | |
| 14 | RFI Rk - RBI Ctr | 1+1+2 | 38 | LBI | 1 |
| 15 | LFO Rk - LBO Ctr | 1+1+2 | 39 | RBO | 2 |
| | xover | | 40 | LBO | 2 |
| 16 | RFI | 2 | 41 | RFO 3-3-3 | 1+1+1+1 |
| 17 | LFO | 2 | | push wide | |
| 18 | CR-RFO 3 | 2+2 | 42a | LBO 3 | 2+1 |
| 19 | LBO | 2 | 42b | LFI | |
| | xover | | | op Mo | |
| 20 | RBI | 2 | 43 | RBI | 1 |
| 21 | LBO | 2 | | push wide | |
| | xover | | 44a | LBO 3 | 2+1 |
| 22 | RBI | 2 | 44b | LFI | |
| 23 | LFO 3 jump | 2+2 | | op Mo | |
| 24 | RFO 3 jump | 2+2 | 45 | RBI | 1 |
| 25 | LFO 3 jump | 2+2 | 46 | LBO | 4 |
| 26 | RBO | 2 | 47 | T Stop - right toe behind | 4 |
| | xover | | | | |
| | | | | | |
| | | | | | |

3. Expanding Exercises (CCW)

FOCUS: Edge quality and Balance

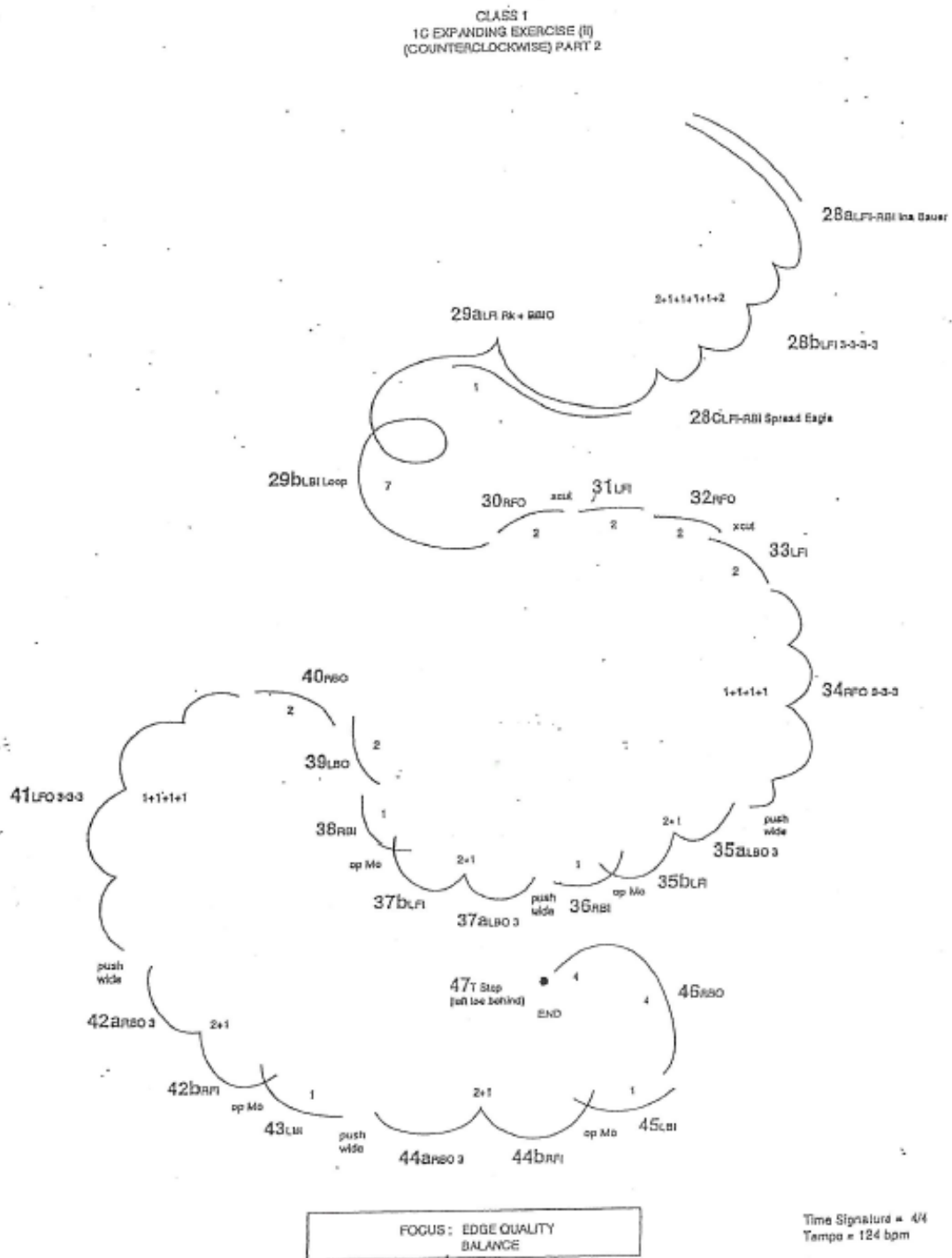

3. Expanding Exercises (CCW)

FOCUS: Edge quality and Balance

| Step No. | Step | No. of Beats | Step No. | Step | No. of Beats |
|----------|-----------------------------------|--------------|----------|----------------------------------|--------------|
| 1 | LF | 2 | 27 | RBI | 2 |
| 2 | RF | 2 | 28a | LFI-RBI Ina Bauer | 2+ |
| | | | 28b | LFI 3-3-3-3 | 1+ 1+1+1 |
| | | | 28c | LFI-RBI Spread Eagle | +2 |
| 3 | LFO | 2 | 29a | LFI Rk + RBIO (both feet on ice) | 1+7 |
| | xover | | 29b | LBI Loop | |
| 4 | RFI | 2 | 30 | RFO | 2 |
| 5 | LFOIO | 4+1+1 | | xover | |
| | xover | | 31 | LFI | 2 |
| 6 | RFI | 2 | 32 | RFO | 2 |
| 7 | LFO-SR | 4 | | xover | |
| | Followed by a very short RBI push | | 33 | LFI | 2 |
| 8 | LFO-SR | 4 | 34 | RFO 3-3-3 | 1+1+1+1 |
| | Followed by a very short RBI push | | | push wide | |
| 9 | LFO | 2 | 35a | LBO 3 | 2+1 |
| | xover | | 35b | LFI | |
| 10 | RFI | 2 | | op Mo | |
| 11a | LFO Rk | 3+4+3+2 | 36 | RBI | 1 |
| 11b | LBO Bracket | | | push wide | |
| 11c | LFI 3 | | 37a | LBO 3 | 2+1 |
| 12 | LBO Pivot | 8 | 37b | LFI | |
| 13 | LFO Pivot | 4 | | op MO | |
| 14 | LFI Rk - LBI Ctr | 1+1+2 | 38 | RBI | 1 |
| 15 | RFO Rk - RBO Ctr | 1+1+2 | 39 | LBO | 2 |
| | xover | | 40 | RBO | 2 |
| 16 | LFI | 2 | 41 | LFO 3-3-3 | 1+1+1+1 |
| 17 | RFO | 2 | | push wide | |
| 18 | CR-LFO 3 | 2+2 | 42a | RBO 3 | 2+1 |
| 19 | RBO | 2 | 42b | RFI | |
| | xover | | | op Mo | |
| 20 | LBI | 2 | 43 | LBI | 1 |
| 21 | RBO | 2 | | push wide | |
| | xover | | 44a | RBO 3 | 2+1 |
| 22 | LBI | 2 | 44b | RFI | |
| 23 | RFO 3 jump | 2+2 | | op Mo | |
| 24 | LFO 3 jump | 2+2 | 45 | LBI | 1 |
| 25 | RFO 3 jump | 2+2 | 46 | RBO | 4 |
| 26 | LBO | 2 | 47 | T Stop - left toe behind | 4 |
| | xover | | | | |
| | | | | | |
| | | | | | |

ADULT STROKING TEST REQUIREMENTS

| | | |
|--------------------|---------------|--|
| ELEMENTARY | TEST 0 | Perimeter Stroking Basic Consecutive Edges |
| PRELIMINARY | TEST 1 | Figure 8 Crossovers (Forward and Backward) Forward and Backward Perimeter Power Skating |
| BRONZE | TEST 2 | Five Step Mohawk Alternating Forward Inside Three-Turns Alternating Backward Crossovers to BO Edges Forward Power Three-Turns |
| SILVER | TEST 3 | FO-BI Three-Turns in the Field FI-BO Three-Turns in the Field Cross-steps Forward and Backward Eight Step Mohawk Backward Power Three-Turns |
| GOLD | TEST 4 | Forward Double 3-turns Backward Double 3-turns Backward Power Circles Inside Slide Chasse Pattern |
| GOLD STAR | TEST 5 | Brackets in the Field Inside Three-Turns/Rocker Choctaws Forward & Backward Counters (choice of inside or outside) Forward & Backward Rockers (choice of inside or outside) |